

**B-06-25-26
PROJECT MANUAL**

**PROJECT/CONTRACT NUMBER:
SS00001001/CP7152**

**IH Special Services Growth
and Support Center
(Bus Drop-Off)**

**Volume 2
Drawings and Technical Specifications**

EAST SIDE UNION HIGH SCHOOL DISTRICT

April 21, 2026

EAST SIDE UNION HIGH SCHOOL DISTRICT SPECIAL SERVICES GROWTH & SUPPORT CENTER IMPROVEMENT PROJECT PROJECT NO. SS00001001/CP7047

PE Pavement Engineering Inc.
You can ride on our reputation

Corporate Office:
3485 Sacramento Drive, Suite A
San Luis Obispo, CA 93401
805.781.2265

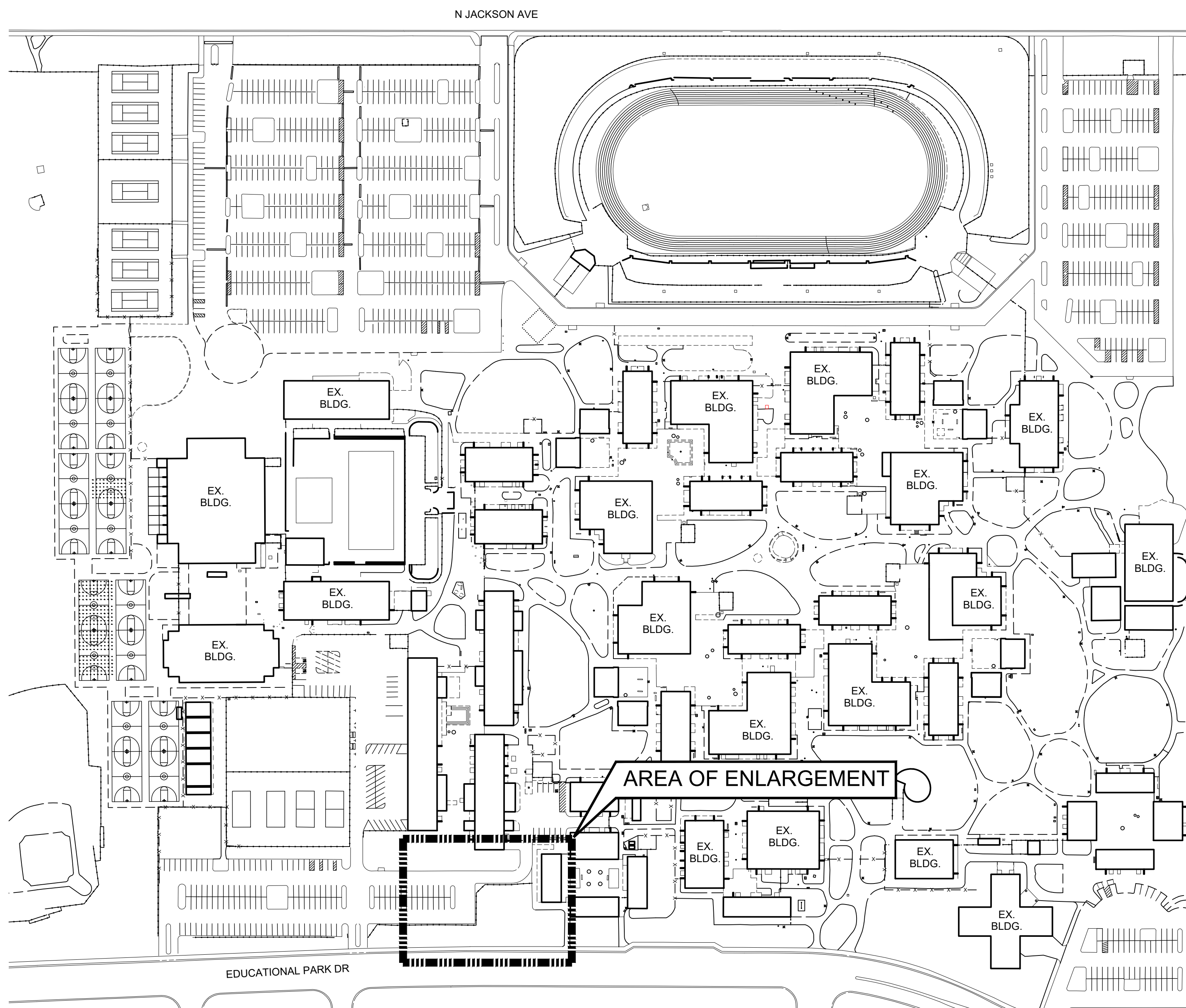

SITE PLAN
NTS

SHEET INDEX	
SHEET NO.	SHEET DESCRIPTION
1	TITLE SHEET
2	AREA OF ENLARGEMENT - DEMO PLAN
3	AREA OF ENLARGEMENT - SITE PLAN
4	AREA OF ENLARGEMENT - GRADING PLAN
5	AREA OF ENLARGEMENT - STRIPING PLAN
6	DETAILS

NOTES:

- CONTRACTOR SHALL BE RESPONSIBLE FOR ANY AND ALL TESTING THAT MAY BE REQUIRED TO LEGALLY DISPOSE OF EXCESS MATERIAL.
- ALL WORK SHALL BE PERFORMED IN ACCORDANCE WITH THE PLANS & CONTRACT DOCUMENTS. WORK NOT COMPLYING WITH PLANS & CONTRACT DOCUMENTS WILL BE SUBJECT TO REMOVAL AND REPLACEMENT AT THE CONTRACTORS EXPENSE.
- THE CONTRACTOR SHALL REMOVE ALL CONSTRUCTION DEBRIS AND LEAVE WORK AREA CLEAN DAILY.
- ABSOLUTE ACCURACY OF DRAWING CAN NOT BE GUARANTEED. WHILE EVERY EFFORT HAS BEEN MADE TO COORDINATE THE LOCATION OF THE EXISTING EQUIPMENT, PIPING, ETC. IT IS THE RESPONSIBILITY OF THE CONTRACTOR TO COORDINATE THE EXACT REQUIREMENTS GOVERNED BY ACTUAL JOB CONDITIONS.
- CONTRACTOR SHALL RESTRIPE ALL AREAS THAT ARE DISTURBED DURING CONSTRUCTION TO MATCH EXIST. STRIPING LAYOUTS UNLESS SHOWN OTHERWISE ON PLANS.
- AREAS NOT IN SCOPE OF WORK DISTURBED DURING CONSTRUCTION SHALL BE RESTORED TO THE EXISTING CONDITION AT THE CONTRACTORS EXPENSE.
- PROTECT EXISTING BUILDING STRUCTURES, AND ADJACENT FINISHED SURFACES DURING CONSTRUCTION. PATCH, REPAIR AND REFINISH AREAS DAMAGED OR IMPACTED BY WORK DURING THIS PROJECT TO MATCH ADJACENT UNDISTURBED AREAS. PATCHING, REPAIRING AND REFINISHING IS TO BE PERFORMED BY WORKMEN SKILLED IN THE TRADES INVOLVED.
- CONTRACTOR SHALL HAVE LOCATING SERVICE VERIFY LOCATION OF ALL EXISTING UTILITIES PRIOR TO EXCAVATION. CONTRACTOR SHALL CONTACT THE ENGINEER TO REVIEW AND ADDRESS ANY UTILITIES CONFLICTING WITH THE SCOPE OF WORK.
- UTILITY BOXES IN CONSTRUCTION AREAS SHALL BE REPLACED AND ADJUSTED TO FINISHED GRADE.
- ANY AND ALL IRRIGATION LINES AND SPRINKLERS IN WORK AREA SHALL BE RELOCATED & ADJUSTED TO GRADE AS NECESSARY TO PROVIDE FULL COVERAGE.
- CONTRACTOR SHALL CLEAN OUT ALL THE DRAINAGE STRUCTURES WITHIN LIMITS OF WORK, INCLUDING DROP INLETS. FLUSH STORM DRAIN LINES PRIOR TO COMMENCEMENT OF WORK. ANY BLOCKAGE SHALL BE CORRECTED PRIOR TO ANY CONSTRUCTION.
- ALL MATERIALS AND WORKMANSHIP ARE SUBJECT TO REVIEW BY OWNER. ANY PORTION OF THE WORK FOUND TO BE DEFECTIVE SHALL BE REPLACED BY THE CONTRACTOR PER CONTRACT AT NO ADDITIONAL COST TO THE OWNER.
- ALL NEW CONCRETE SHALL BE DOWELED & EPOXIED INTO EXISTING CONCRETE WITH #4 REBAR X 12" MIN. @ 24" O.C.
- ALL AREAS OF PCC CHIPPED OR DAMAGED DURING CONSTRUCTION SHALL BE REMOVED AND REPLACED BACK TO THE NEXT JOINT.
- CONTRACTOR SHALL NOT CUT ANY ROOTS GREATER THAN 2" IN DIAMETER WITHOUT PRIOR APPROVAL FROM THE SCHOOL DISTRICT'S ARBORIST. ANY ROOTS WITHIN 4' OF THE TRUNK OF ANY OF THE TREES IN THE PROJECT SHALL NOT BE CUT FOR ANY REASON.
- CONTRACTOR RESPONSIBLE TO OBTAIN ALL NECESSARY PERMITS PRIOR TO CONSTRUCTION.

EAST SIDE UNION HIGH SCHOOL DISTRICT
INDEPENDENCE HIGH SCHOOL
617 NORTH JACKSON AVENUE, SAN JOSE, CA
SPECIAL SERVICES GROWTH & SUPPORT CENTER
TITLE SHEET

DRAWN BY: JT
PROJECT NUMBER: 260061-01
SCALE: NTS
VERIFY SCALE
BAR REPRESENTS
1" ON ORIGINAL
DATE: APRIL 2026
SHEET NUMBER:

P:\R\Z\SHARED\DRIVE\ACTIVE PROJECTS\EAST SIDE UNION HIGH SCHOOL DISTRICT\SS00001001\DESIGN\DRAWINGS\260061-01_INDEPENDENCE HIGH SCHOOL (BUS TURNOUT).DWG Plot Date: 4/21/2026 11:29 AM

P:\01 - 2025\DRIVEACTIVE PROJECTS\EAST SIDE UHSD\260061-01_INDEPENDENCE HIGH (BUS TURNOUT)\TASK 01 - DESIGN\DRAWINGS\260061-01_INDEPENDENCE HIGH SCHOOL (BUS TURNOUT).DWG - Plot Date: 4/21/2026 11:29 AM

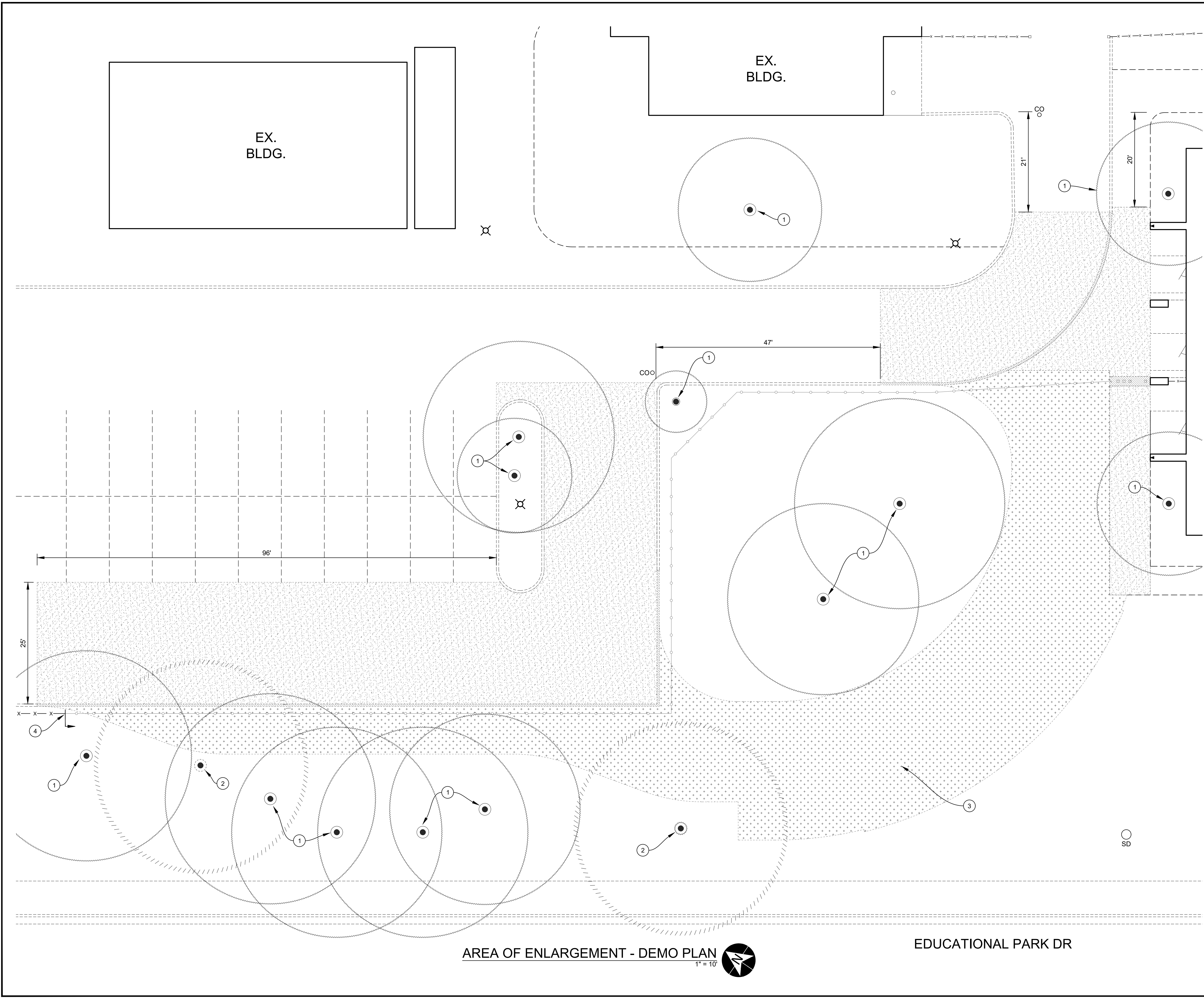

LEGEND

- REMOVE & DISPOSE OF PCC
- REMOVE & DISPOSE OF HMA
- LANDSCAPE REMOVAL (SEE NOTE NO.3)
- FENCE (EX.)
- REMOVE & DISPOSE OF FENCE POST, FOOTINGS & FABRIC
- LIGHT STANDARD (EX.)
- HMA
- PCC
- CO
- SD

CONSTRUCTION NOTES:

1. INSTALL STRAW WATTLE TO PROTECT EX. TREES DURING CONSTRUCTION. STRAW WATTLE TREE PROTECTION TO BE WRAPPED AROUND THE TRUNK OF THE TREE TO A MINIMUM HEIGHT OF 6 FEET ABOVE EXISTING GRADE AT THE BASE OF THE TREE. WATTLES TO BE MOVED AS SOON AS POSSIBLE AFTER THE CONSTRUCTION IMPACTS ARE COMPLETED AROUND THE TREE.
2. REMOVE & DISPOSE OF EX. TREE, TRUNK & ROOT BALL.
3. CLEAR & GRUB EX. PLANT MATERIAL, INCLUDING ROOTS, TURF, ETC. STOCKPILE NATIVE SOIL ON SITE AT A LOCATION APPROVED BY THE DISTRICT. REMOVE IRRIGATION PIPING WITHIN THE DEMOLITION ZONE. CAP OR REROUTE IRRIGATION LINES AS NEEDED TO MAINTAIN IRRIGATION TO LANDSCAPE AREAS WHICH ARE TO REMAIN.
4. FENCE REMOVAL TO BEGIN AT THIS LOCATION.

NOTES:

1. LIMITS OF DEMOLITION TO BE LOCATED AND APPROVED BY THE ENGINEER PRIOR TO EXCAVATION. ANY OVERCUTS DURING DEMOLITION SHALL BE PAID FOR AT THE CONTRACTORS EXPENSE.

AREA OF ENLARGEMENT - DEMO PLAN
1" = 10'

EDUCATIONAL PARK DR

Pavement Engineering Inc.
You can ride on our reputation
Corporate Office:
3485 Sacramento Drive, Suite A
San Luis Obispo, CA 93401
805.781.2265

EAST SIDE UNION HIGH SCHOOL DISTRICT
INDEPENDENCE HIGH SCHOOL 617 NORTH JACKSON AVENUE, SAN JOSE, CA
SPECIAL SERVICES GROWTH & SUPPORT CENTER
AREA OF ENLARGEMENT - DEMO PLAN

DRAWN BY: JT
PROJECT NUMBER: 260061-01
SCALE: 1" = 10'
VERIFY SCALE
BAR REPRESENTS 1" ON ORIGINAL
DATE: APRIL 2026
SHEET NUMBER:

BORING LOG				
NO.	AC	AB	R-VALUE	FABRIC (Y/N)
B1	6.75"	6"	---	N
B2	3.5"	7.5"	21	N

*CORING DATA IS FOR INFORMATION ONLY. EXISTING SECTION MAY VARY FROM SECTION(S) FOUND AT CORING LOCATION(S). FABRIC MAY BE PRESENT IN SECTIONS EVEN IF NOT FOUND AT CORING LOCATION(S).

- ### LEGEND
- SOIL TREATMENT, PLACE AB & HMA PAVING
 - REMOVE & REPLACE 4" HMA
 - REMOVE & REPLACE 6" HMA
 - NEW (OR) RECONSTRUCT PCC FACILITIES
 - INSTALL DETECTABLE WARNING SURFACE
 - REGRADE & RESEED LANDSCAPE
 - BRICKS (EX., TO REMAIN)
 - INSTALL 6' TALL CHAIN-LINK FENCE
 - INSTALL PCC CURB
 - INSTALL RETAINING PCC CURB
 - INSTALL PCC CURB & GUTTER
 - INSTALL 6" SCH40 PVC DRAIN PIPE
 - INSTALL 3" SCH40 PVC SLEEVE
 - FENCE (EX.)
 - DRAINAGE DIRECTION (6" DRAIN PIPE)
 - BORE LOCATION (SEE BORING LOG)
 - DOWNSPOUT (EX.)
 - LIGHT STANDARD (EX.)
 - EX. TREE TO REMAIN
 - AGGREGATE BASE
 - HOT MIX ASPHALT
 - PORTLAND CEMENT CONCRETE
 - CLEANOUT (EX.)
 - DROP INLET
 - STORM DRAIN (EX.)
 - DETAIL NUMBER
PAGE NUMBER

- ### CONSTRUCTION NOTES:
- 1 GRADE & LIME TREAT TO 12" DEPTH; PLACE 6" CLASS II AB (COMPACT TO 95%R.C.) & 4" HMA.
 - 2 REMOVE & REPLACE 4" HMA.
 - 3 REMOVE & REPLACE 6" HMA.
 - 4 INSTALL PCC SIDEWALK W/ TYPE A1 INTEGRAL CURB.
 - 5 INSTALL TYPE C1 INTEGRAL PCC SIDEWALK, CURB & GUTTER.
 - 6 INSTALL TYPE C PCC RAMP W/ DETECTABLE WARNING SURFACE & TYPE C2 INTEGRAL CURB & GUTTER.
 - 7 REMOVE & REPLACE OR INSTALL PCC CURB.
 - 8 INSTALL PCC RETAINING CURB.
 - 9 INSTALL CHRISTY MODEL V64 DRAIN INLET W/ V64-7 GRATE, PCC APRON & EXTENSIONS AS REQUIRED.
 - 10 INSTALL PCC CURB & GUTTER.
 - 11 INSTALL 6' TALL CHAIN-LINK FENCE IN LANDSCAPE.
 - 12 NOT USED.
 - 13 PRUNE & REMOVE TREE ROOTS.
 - 14 PROTECT EX. FACILITIES DURING CONSTRUCTION.
 - 15 RE-ROUTE IRRIGATION LINES & REPLACE SPRINKLERS AS NEEDED TO ENSURE EVEN & COMPLETE SPRAY COVERAGE TO REMAINING LANDSCAPE AREAS. ADJUST SPRINKLERS TO ELIMINATE OVERSPRAY ONTO ADJACENT HARDSCAPE SURFACES. (POP-UP SPRINKLER HEADS SET NO FARTHER THAN 2" FROM BACK OF PCC FACILITIES). RESTORE LANDSCAPING AFTER CONSTRUCTION.
 - 16 INSTALL 6" SCH40 PVC DRAIN PIPE (SEE GRADING PLAN FOR PIPE INVERT).
 - 17 REGRADE & RESEED LAWN; MATCH EX. TURF (SEE NOTE NO. 1).
 - 18 INSTALL 3" PIPE SLEEVES FOR FUTURE UTILITY USE. CAP ENDS (NO GLUE) & SET POST MARKER @EACH END (3 EA.).
 - 19 INSTALL/RESTORE IRRIGATION LINES & BUBBLERS.

NOTES:

1. BACKFILL & REGRADE W/ SALVAGED TOPSOIL FIRST; IMPORT CLEAN FILL ONLY IF NEEDED TO MAKE GRADE. ANY EXCESS SOIL TO BE REMOVED & DISPOSED OF BY THE CONTRACTOR.

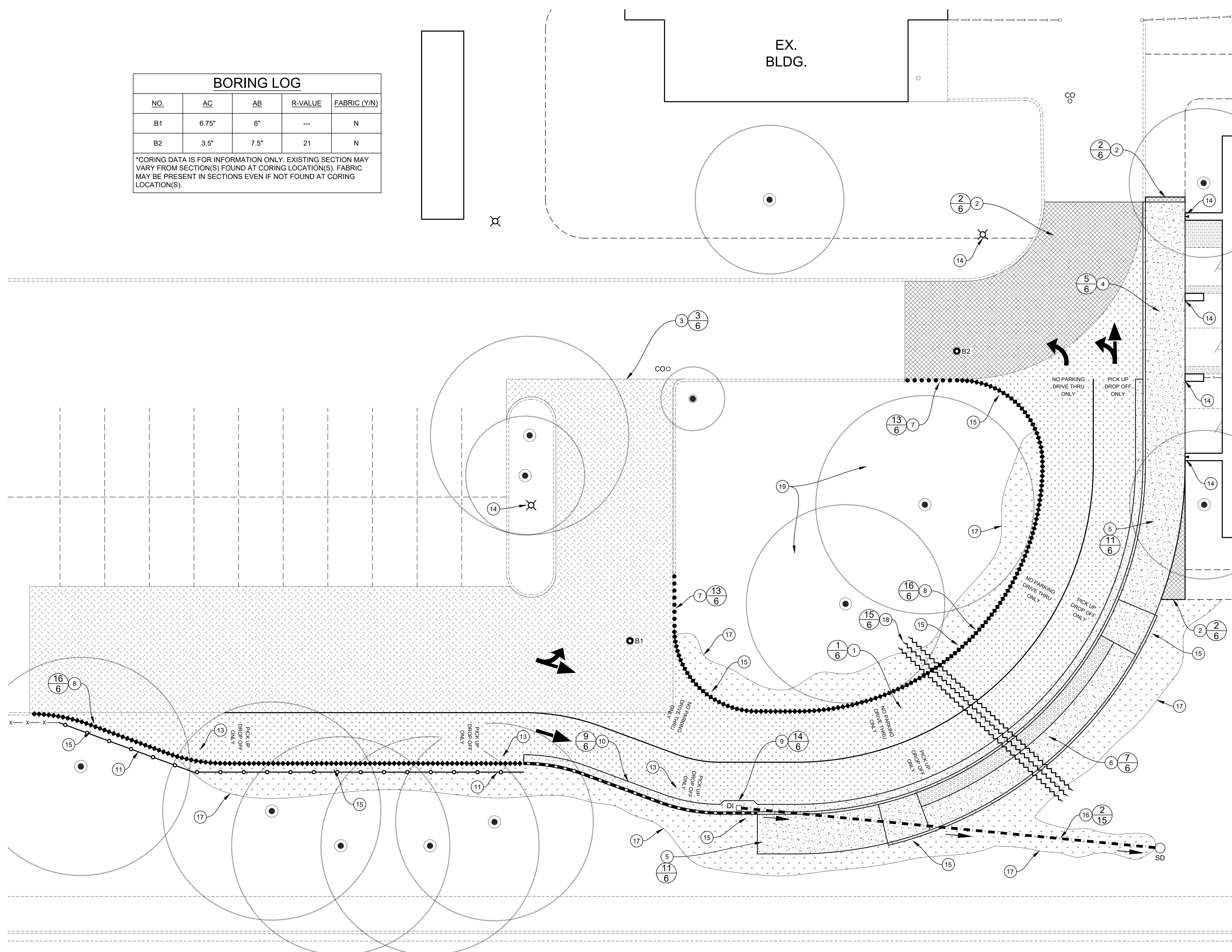

AREA OF ENLARGEMENT - SITE PLAN
1" = 10'

EDUCATIONAL PARK DR

Pavement Engineering Inc.
You can ride on our reputation
Corporate Office:
3485 Sacramento Drive, Suite A
San Luis Obispo, CA 93401
805.781.2265

EAST SIDE UNION HIGH SCHOOL DISTRICT
INDEPENDENCE HIGH SCHOOL
617 NORTH JACKSON AVENUE, SAN JOSE, CA
SPECIAL SERVICES GROWTH & SUPPORT CENTER
AREA OF ENLARGEMENT - SITE PLAN

DRAWN BY: JT
PROJECT NUMBER: 260061-01
SCALE: 1" = 10'
VERIFY SCALE
BAR REPRESENTS 1' ON ORIGINAL
DATE: APRIL 2026
SHEET NUMBER: 3 OF 6

P:\01 - Z SHARED\DRIVE\ACTIVE PROJECTS\EAST SIDE UNION HIGH SCHOOL\DESIGN\DRAWINGS\260061-01_INDEPENDENCE HIGH SCHOOL (BUS TURNOUT).DWG Plot Date: 4/21/2026 11:28 AM

P:\01 - SHARED\DRIVE\ACTIVE PROJECTS\EAST SIDE UHSD\260061-01_INDEPENDENCE HIGH (BUS TURNOUT)\TASK 01 - DESIGN\DRAWINGS\260061-01_INDEPENDENCE HIGH SCHOOL (BUS TURNOUT).DWG - Plot Date: 4/21/2026 11:28 AM

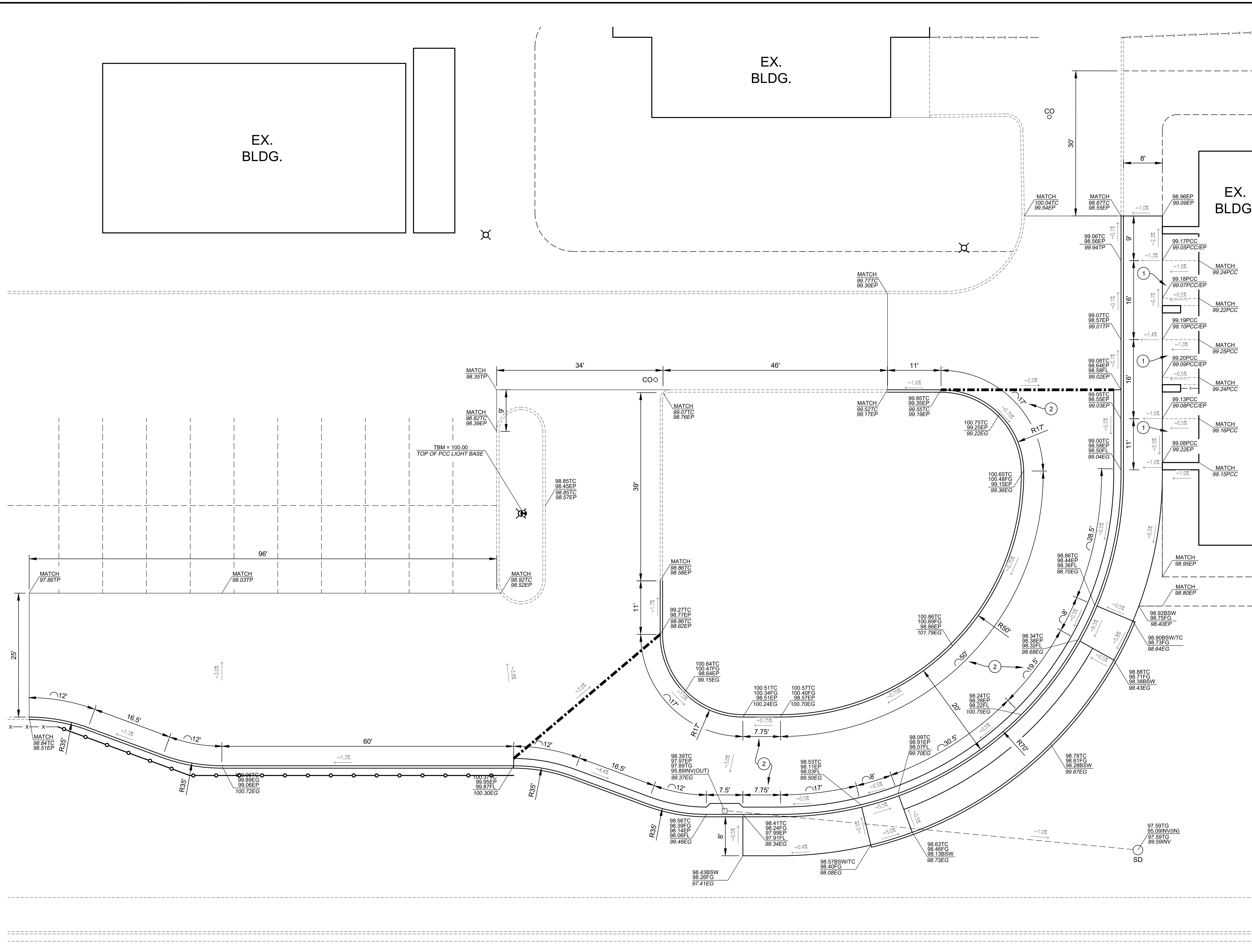

- LEGEND**
- ⊕ TEMPORARY BENCHMARK
 - GRADE BREAK
 - 1.3% DRAINAGE SLOPE
 - INV INVERT
 - PCC PORTLAND CEMENT CONCRETE
 - BSW BACK OF PCC SIDEWALK
 - EG EXISTING GRADE
 - EP EDGE OF PAVEMENT
 - FG FINISH GRADE
 - FL FLOW LINE
 - TC TOP OF PCC CURB
 - TG TOP OF GRATE
 - TP TOP OF PAVEMENT
 - XX.XX DESIGN ELEV.
 - XX.XX EXIST. ELEV.

- CONSTRUCTION NOTES:**
- 1 CONTRACTOR TO VERIFY GRADES & SLOPES W/ FIELD INSPECTOR PRIOR TO CONCRETE POUR.
 - 2 MEASUREMENTS FOR NEW CURB OR CURB & GUTTER ARE DIMENSIONED AT FACE OF CURB.

AREA OF ENLARGEMENT - GRADING PLAN
1" = 10'

EDUCATIONAL PARK DR

Pavement Engineering Inc.
You can ride on our reputation
Corporate Office:
3485 Sacramento Drive, Suite A
San Luis Obispo, CA 93401
805.781.2265

EAST SIDE UNION HIGH SCHOOL DISTRICT
INDEPENDENCE HIGH SCHOOL
617 NORTH JACKSON AVENUE, SAN JOSE, CA
SPECIAL SERVICES GROWTH & SUPPORT CENTER
AREA OF ENLARGEMENT - GRADING PLAN

DRAWN BY: JT
PROJECT NUMBER: 260061-01
SCALE: 1" = 10'
VERIFY SCALE
BAR REPRESENTS 1" ON ORIGINAL
DATE: APRIL 2026
SHEET NUMBER:

Path: Z:\SHAREDR\DRIVEACTIVE PROJECTS\EAST SIDE UNDEPENDENCE HIGH (BUS TURNOUT)\TASK 01 - DESIGN\DRAWINGS\260061-01_INDEPENDENCE HIGH SCHOOL (BUS TURNOUT).DWG Plot Date: 4/21/2026 11:28 AM

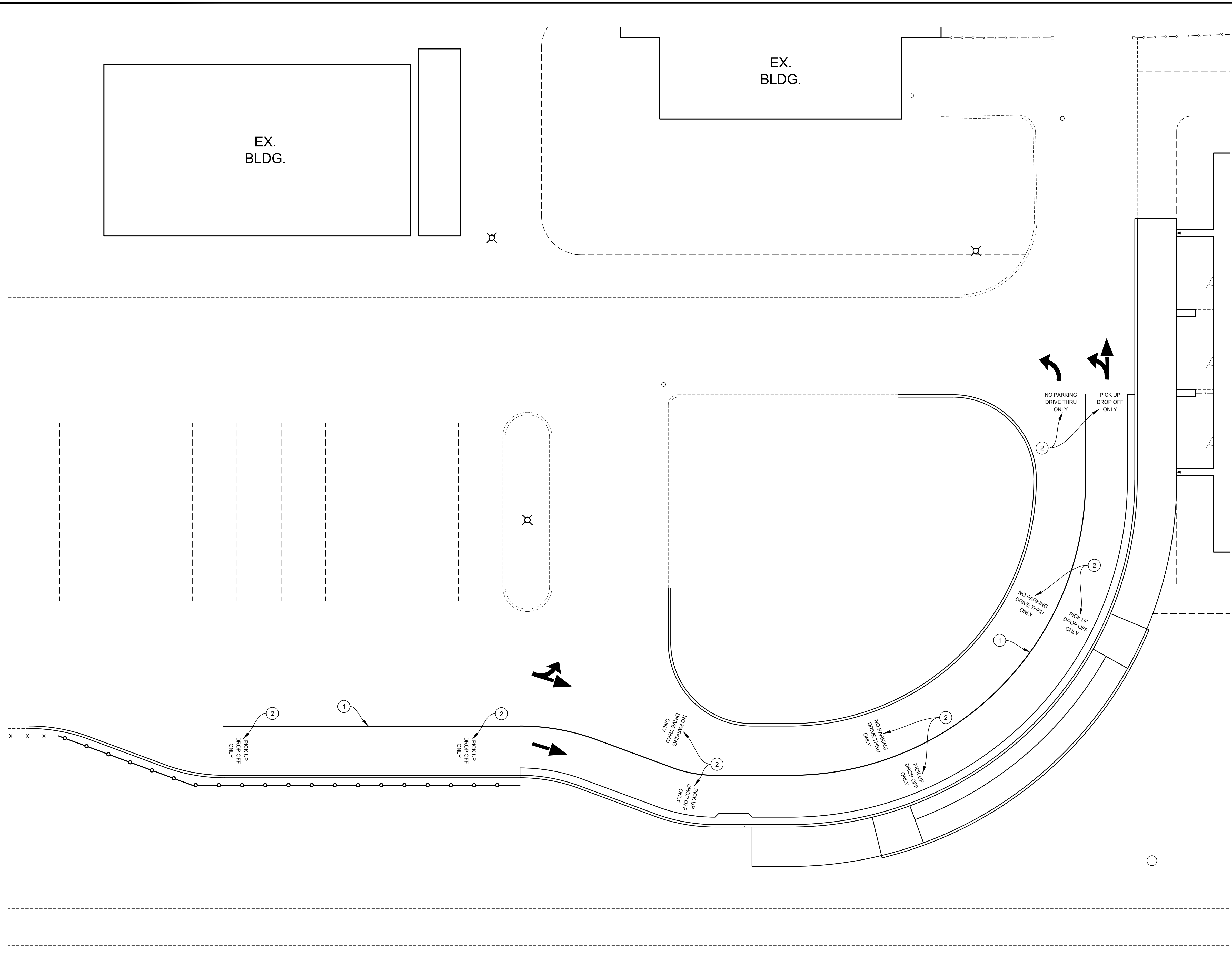

STRIPING NOTES:
1. PAINT ALL STRIPING & PAVEMENT LEGENDS WITH TWO COATS MINIMUM APPLICATION.

CONSTRUCTION NOTES:
① PAINT 4" WIDE WHITE STRIPE.
② PAINT 12" TALL STENCILING.

AREA OF ENLARGEMENT - STRIPING PLAN 1" = 10'

EDUCATIONAL PARK DR



Pavement Engineering Inc.
You can ride on our reputation

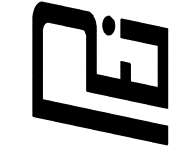

Corporate Office:
3485 Sacramento Drive, Suite A
San Luis Obispo, CA 93401
805.781.2265

EAST SIDE UNION HIGH SCHOOL DISTRICT
INDEPENDENCE HIGH SCHOOL 617 NORTH JACKSON AVENUE, SAN JOSE, CA

SPECIAL SERVICES GROWTH & SUPPORT CENTER
AREA OF ENLARGEMENT - STRIPING PLAN

DRAWN BY: JT
PROJECT NUMBER: 260061-01
SCALE: 1" = 10'
VERIFY SCALE
BAR REPRESENTS 1" ON ORIGINAL
DATE: APRIL 2026
SHEET NUMBER:

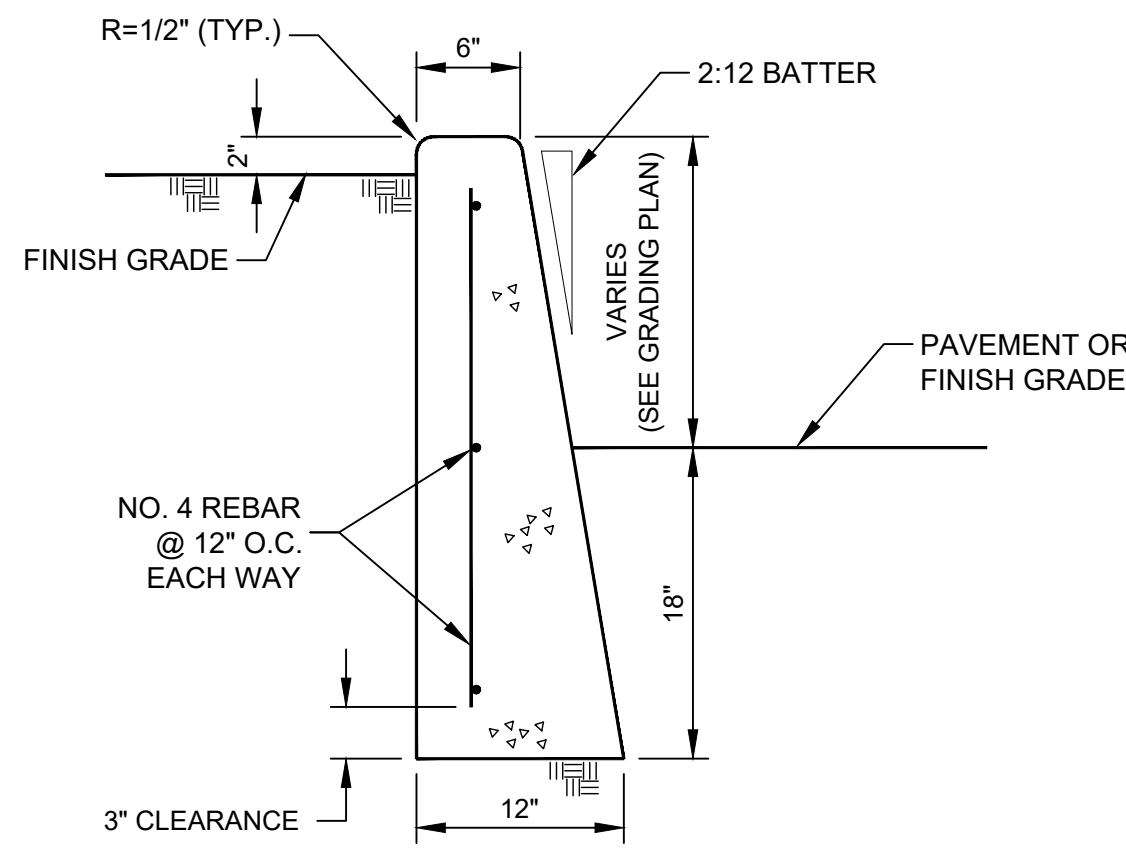

16 PCC RETAINING CURB DETAIL NTS

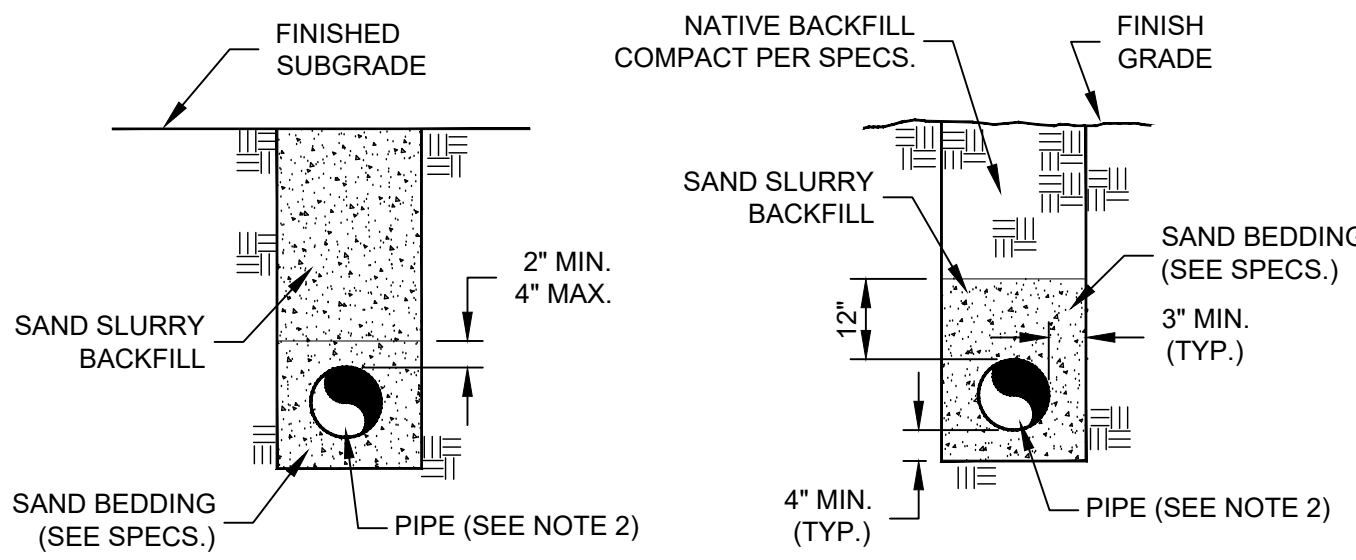

BACKFILL UNDER PAVEMENT BACKFILL UNDER LANDSCAPE

NOTES:
 1) "BACKFILL UNDER PAVEMENT" SHALL APPLY IN ALL AREAS OF EXISTING &/OR NEW PAVEMENT, SIDEWALK, PADS & PAVED WALKWAYS. "BACKFILL UNDER LANDSCAPE" SHALL APPLY IN ALL LANDSCAPE PLANTER AREAS AND ALL AREAS TO REMAIN UNPAVED ACCORDING TO THE PROJECT PLANS.
 2) SEE PLANS FOR PIPE TYPE & SIZE.

15 TYPICAL TRENCH BACKFILL DETAIL NTS

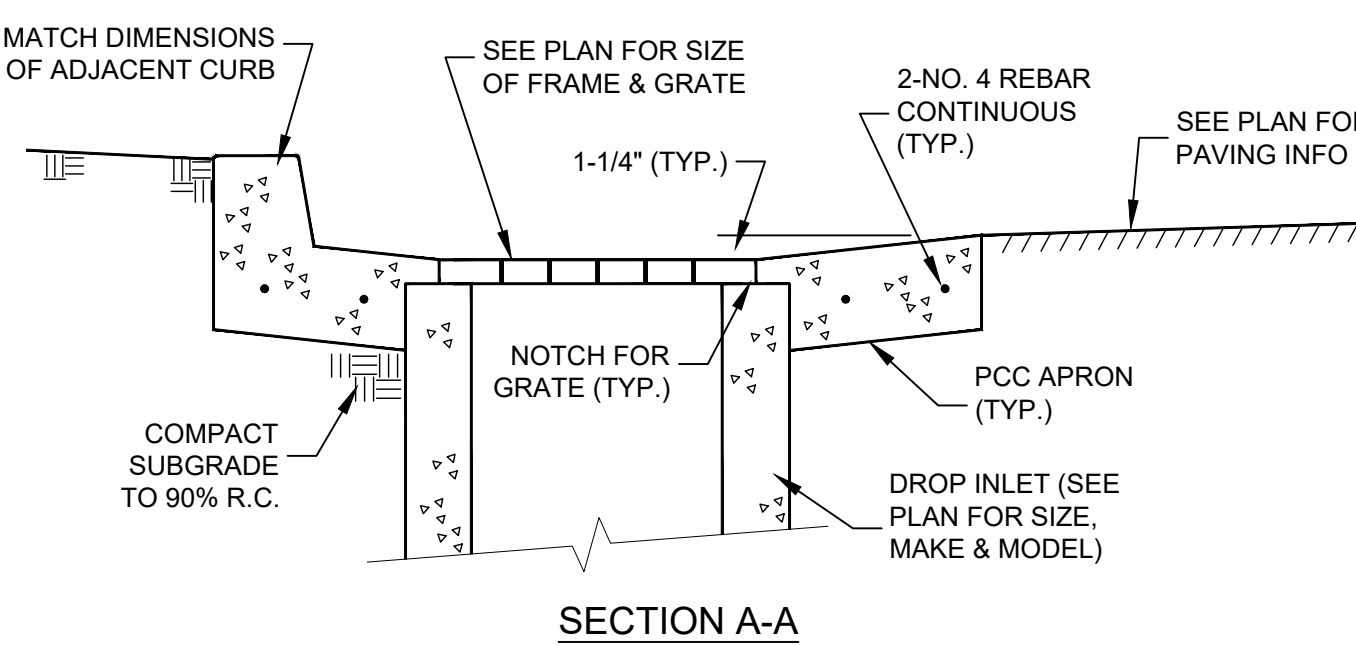
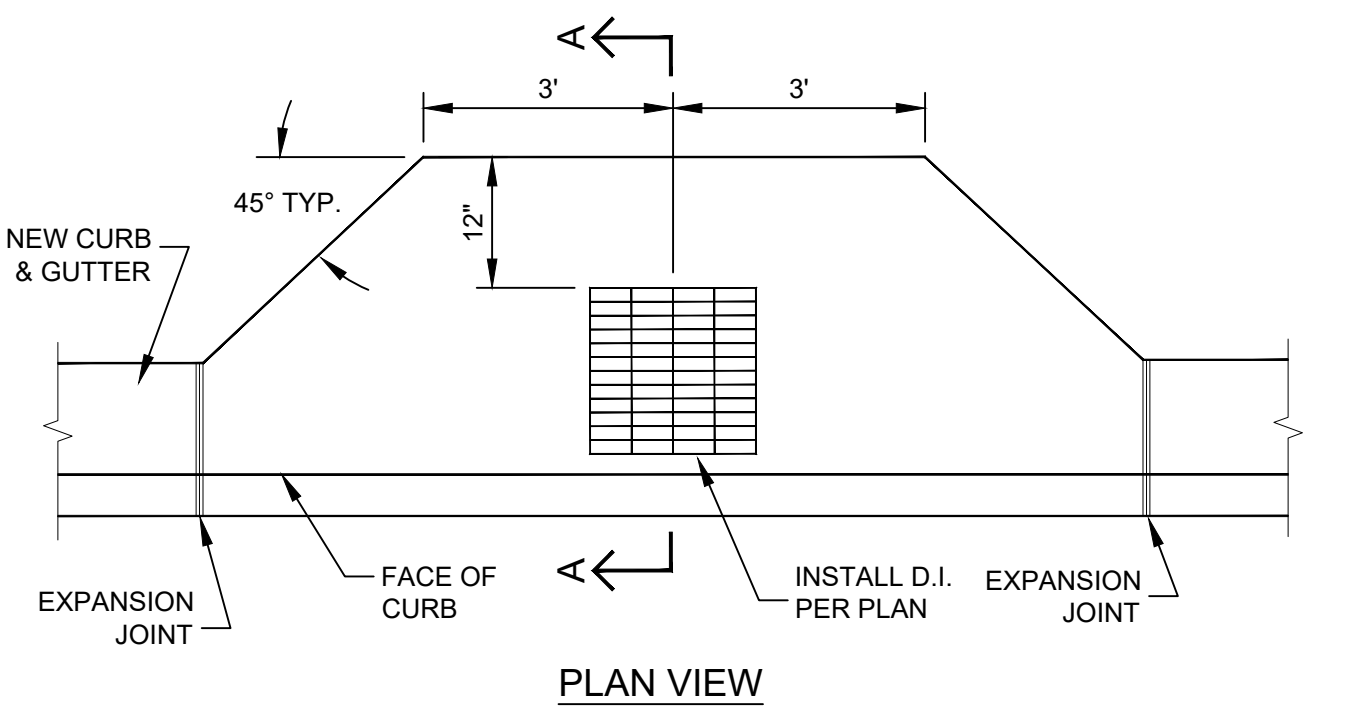

14 PCC APRON @ DROP INLET NTS

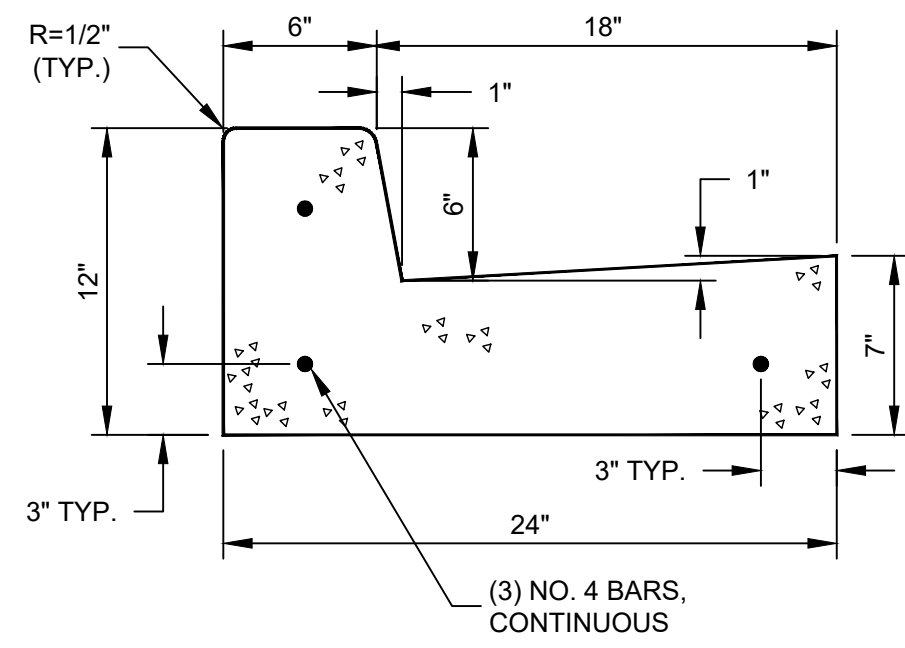

NOTE: CONTROL JOINTS SHALL BE @ 10' O.C. MAXIMUM.

9 PCC CURB & GUTTER DETAIL

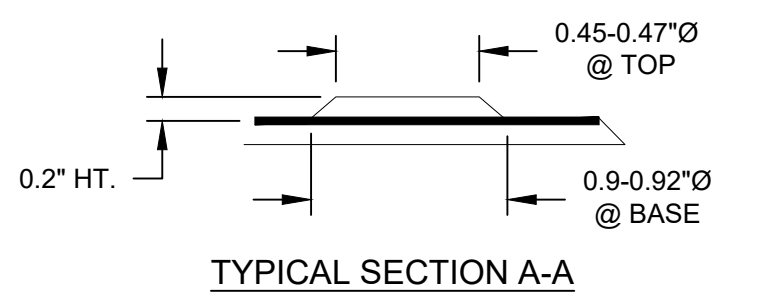
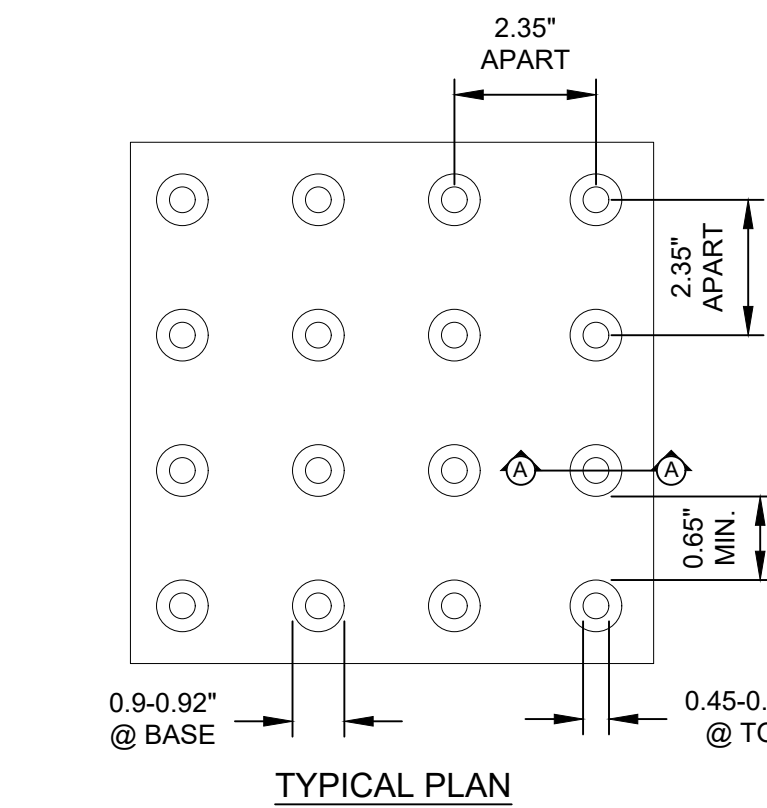

NOTE: TRUNCATED DOMES SHALL COMPLY W/SECTION 11B-705 - 'DETECTABLE WARNINGS' OF THE CBC.

10 TRUNCATED DOMES NTS

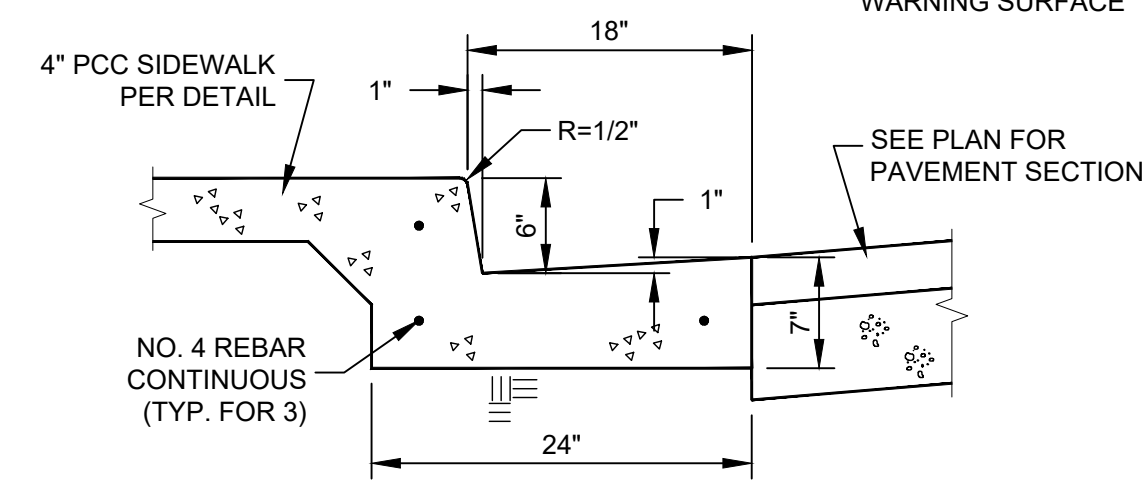

NOTE: CONTROL JOINTS SHALL BE @ 10' O.C. MAX.

11 TYPE C1: INTEGRAL SIDEWALK, CURB & GUTTER NTS

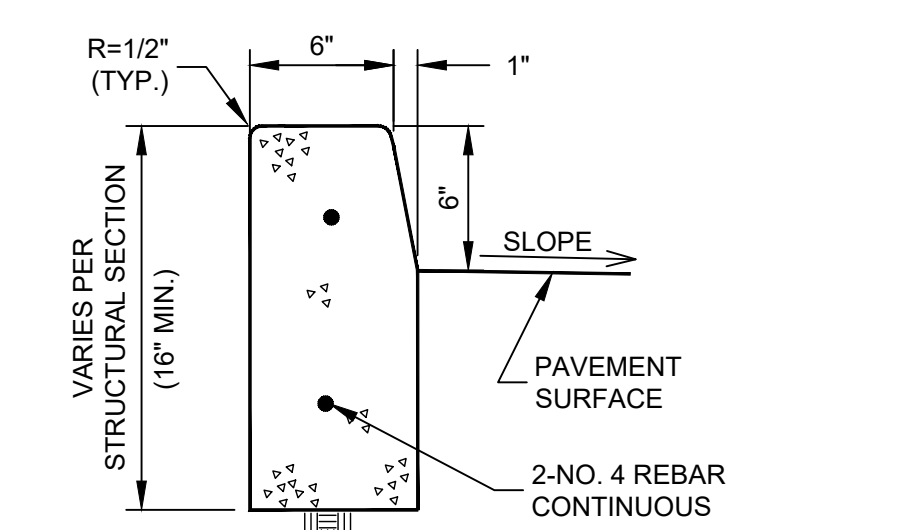

NOTE: CONTROL JOINTS @ 10' O.C. MAXIMUM SEE SPECIFICATIONS FOR REQUIREMENTS

13 PCC CURB DETAIL NTS

8 TYPE C2: INTEGRAL PCC GUTTER W/FLUSH CURB NTS

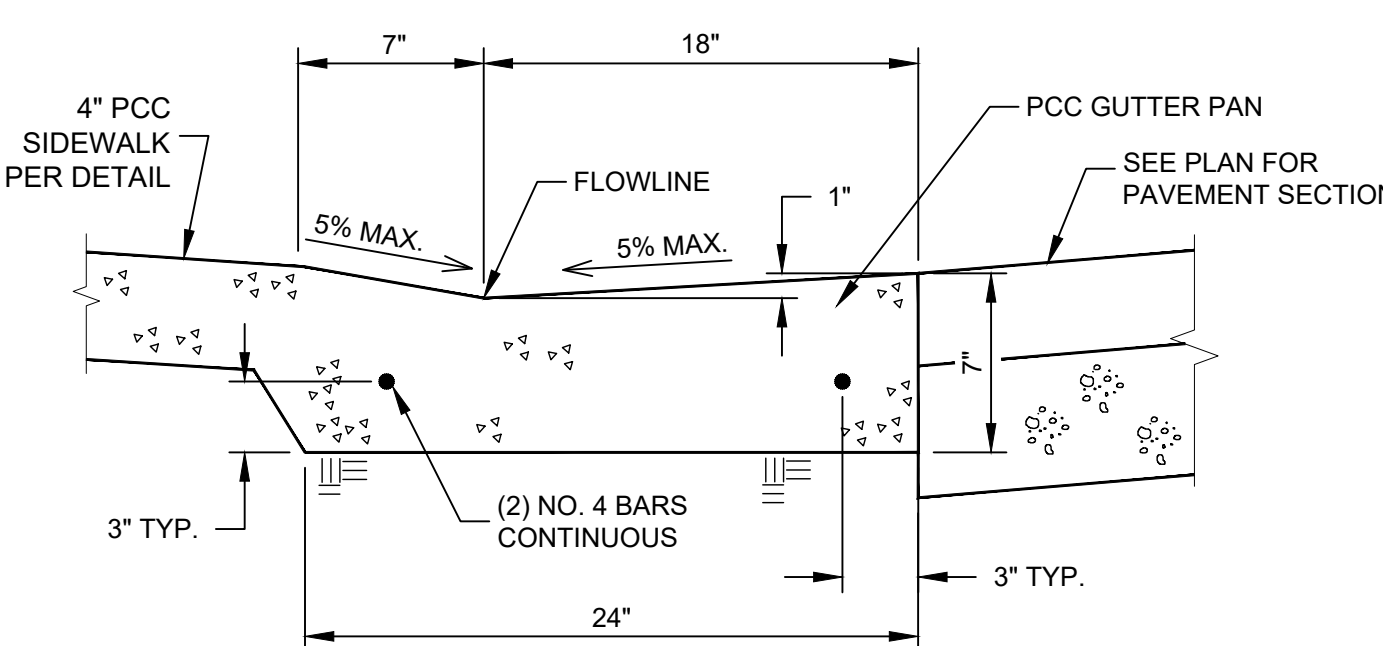

NOTE: CONTROL JOINTS SHALL BE @ 10' O.C. MAXIMUM SEE SPECIFICATIONS FOR REQUIREMENTS

8 TYPE C2: INTEGRAL PCC GUTTER W/FLUSH CURB NTS

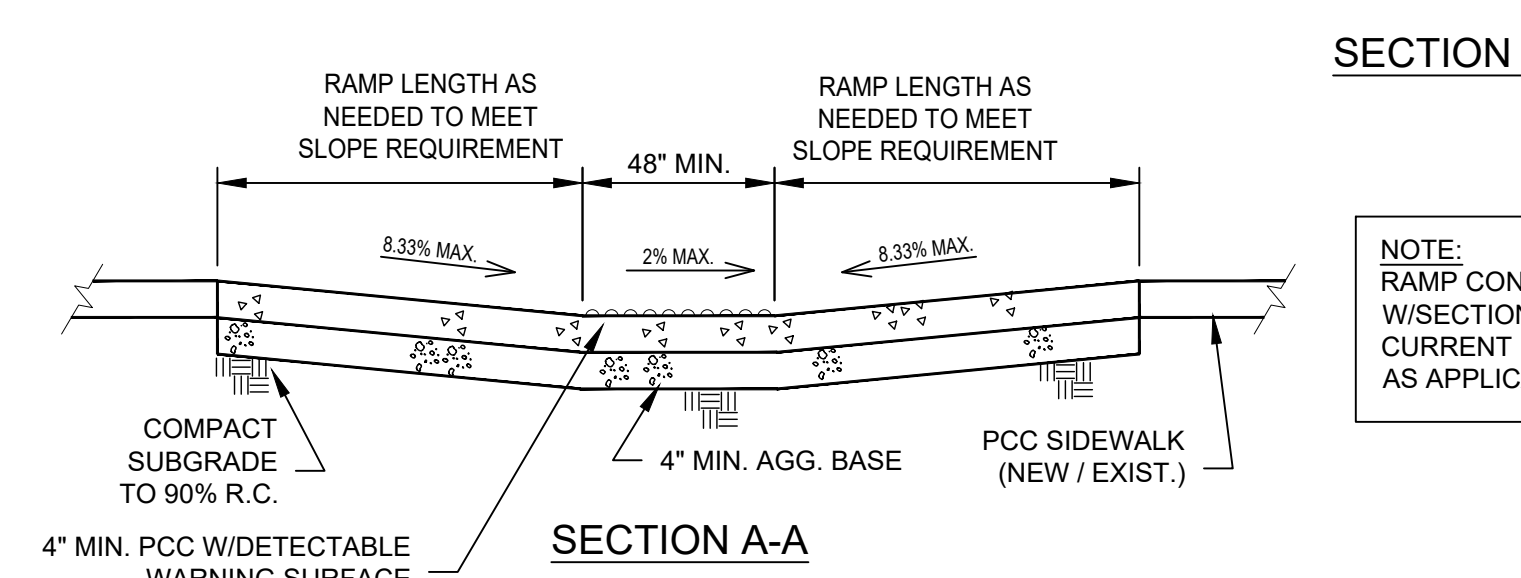
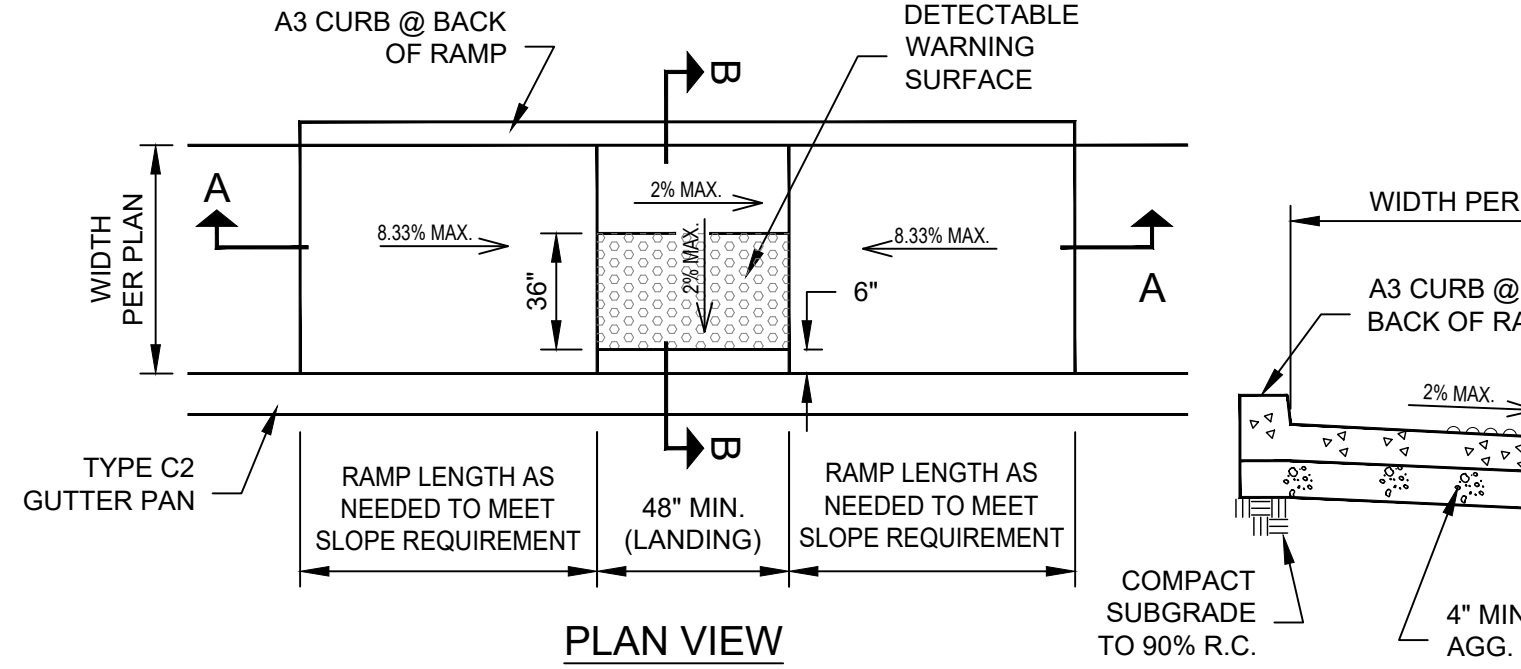

NOTE: RAMP CONSTRUCTION SHALL CONFORM W/SECTION 11B-406 OF THE MOST CURRENT EDITION OF THE CBC AS WELL AS APPLICABLE LOCAL REQUIREMENTS.

7 CURB RAMP TYPE C DETAIL NTS

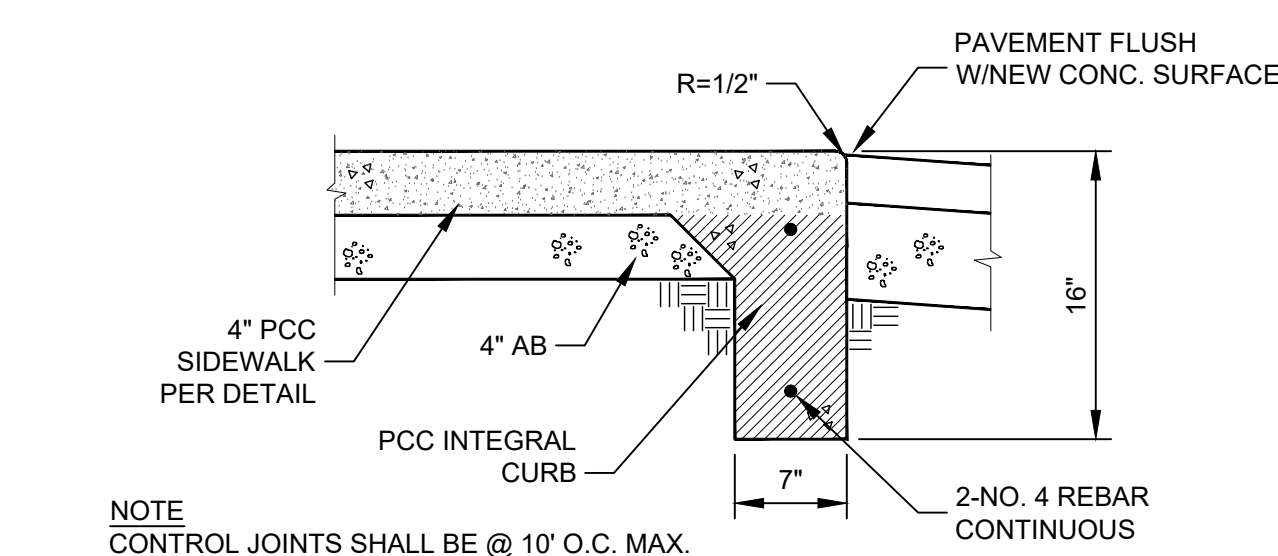

NOTE: CONTROL JOINTS SHALL BE @ 10' O.C. MAX. SEE SPECIFICATIONS FOR REQUIREMENTS.

6 TYPE A2: INTEGRAL SIDEWALK & CURB NTS

12 TYPE A3: INTEGRAL CURB @ LANDSCAPE NTS

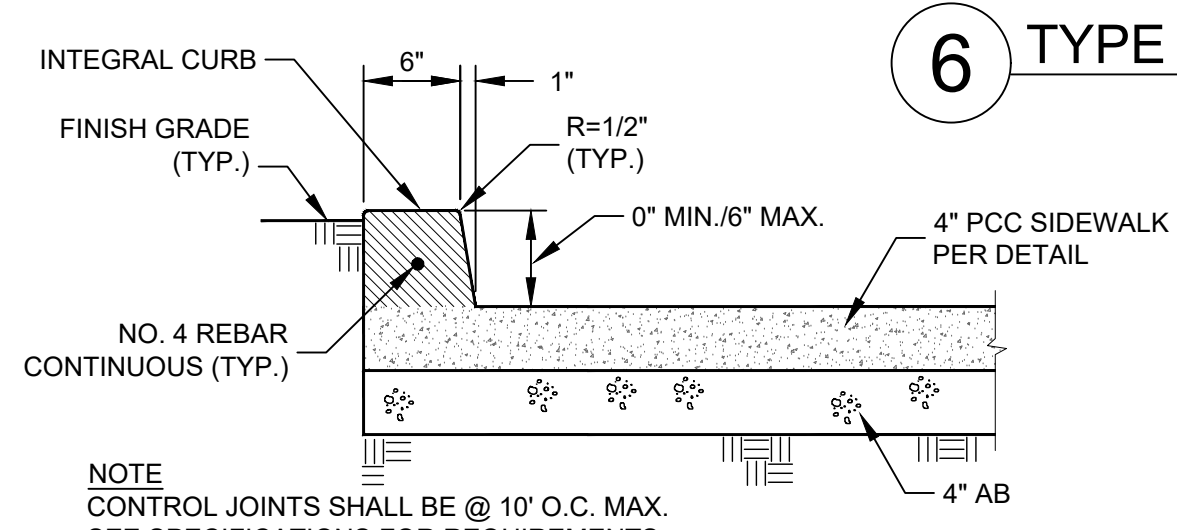

NOTE: CONTROL JOINTS SHALL BE @ 10' O.C. MAX. SEE SPECIFICATIONS FOR REQUIREMENTS.

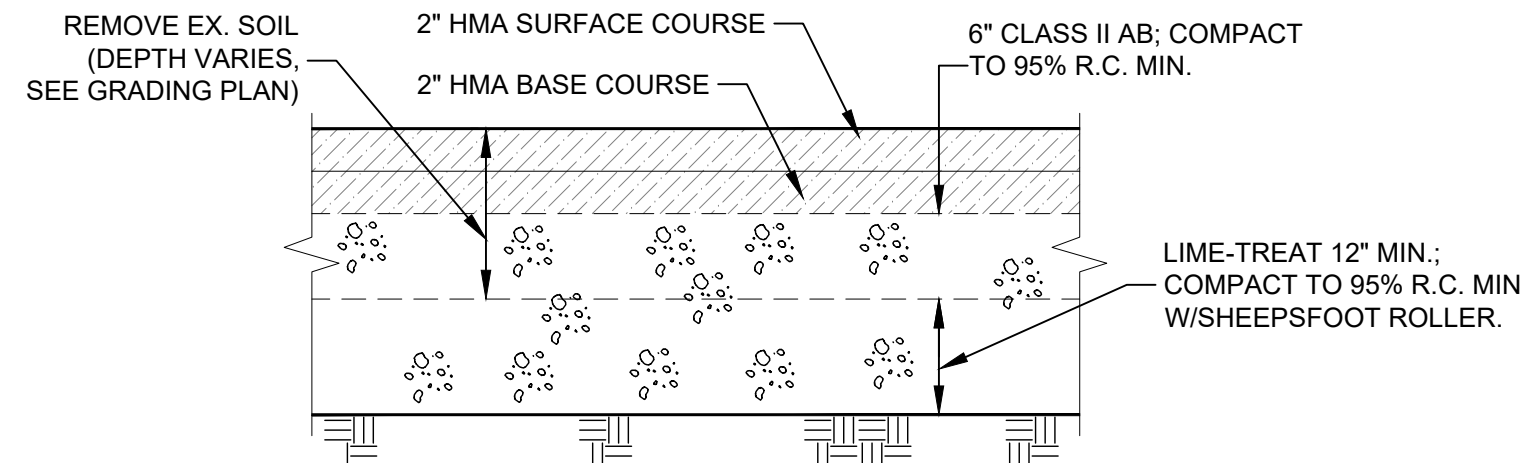

NOTES:
 1. UNDERGROUND SERVICE ALERT (U.S.A.) SHALL BE NOTIFIED PRIOR TO ANY EXCAVATION ON THIS PROJECT. A REFERENCE NUMBER FROM U.S.A. SHALL BE PROVIDED TO CLIENT'S REPRESENTATIVE BEFORE ANY UNDERGROUND EXCAVATION WILL BE ALLOWED.
 2. CONTRACTOR SHALL CONTACT ESUHS&D & SCHEDULE WATER TO BE SHUT OFF PRIOR TO LIME-TREATING, THEN TURNED ON PRIOR TO PAVING TO AVOID PAVING OVER DAMAGED IRRIGATION LINES.
 3. SEE SPECIFICATIONS FOR SOIL TREATMENT INFORMATION.

1 SOIL TREATMENT & HMA PAVING NTS

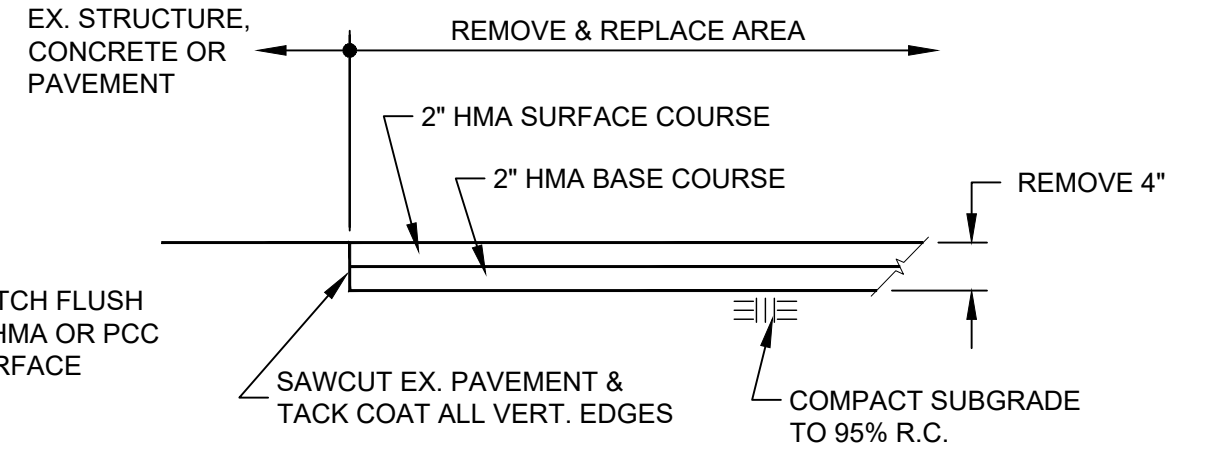

2 REMOVE & REPLACE 4\"/>

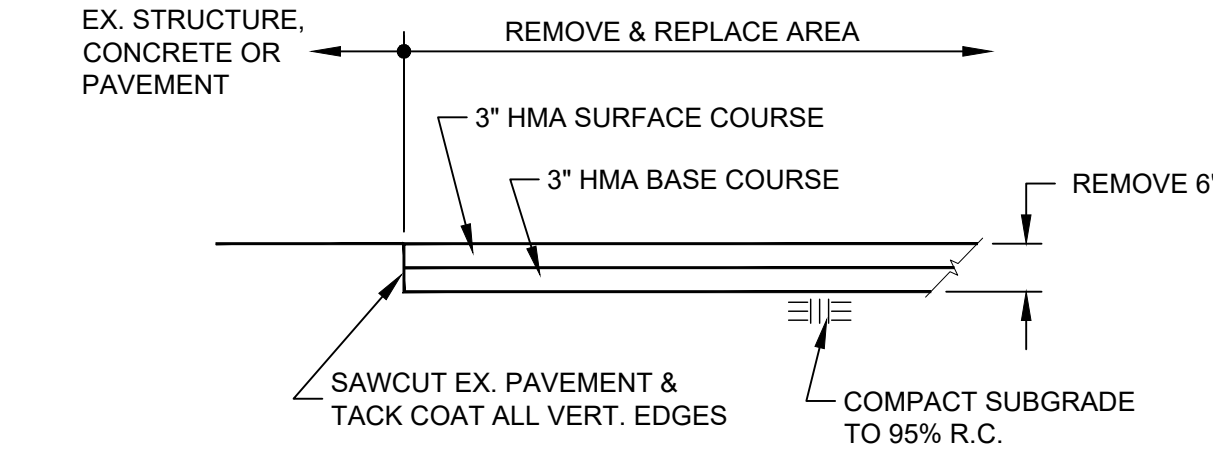

3 REMOVE & REPLACE 6\"/>

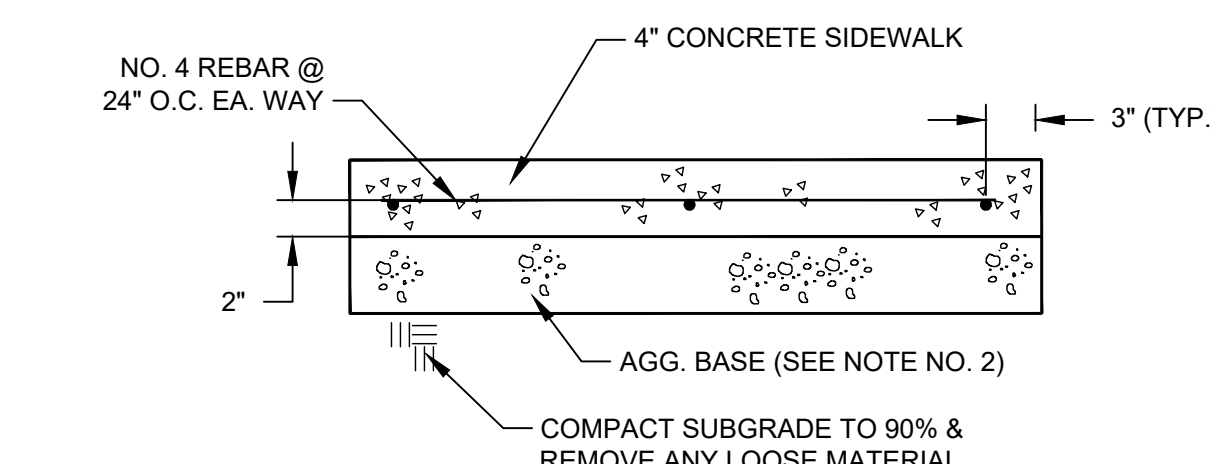

4 PCC SIDEWALK DETAIL NTS

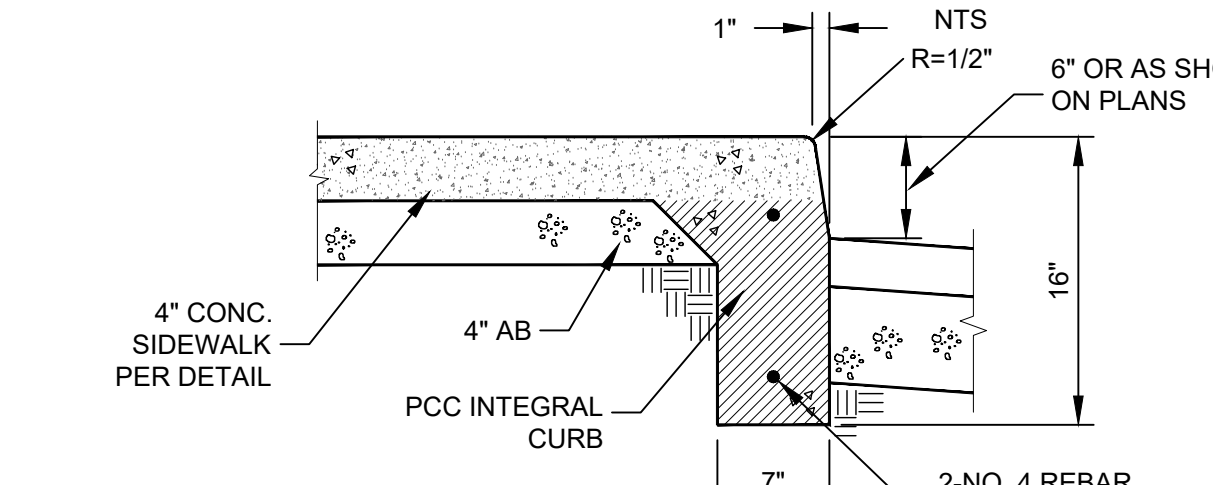

NOTE: CONTROL JOINTS SHALL BE @ 10' O.C. MAX. SEE SPECIFICATIONS FOR REQUIREMENTS.

5 TYPE A1: INTEGRAL SIDEWALK & CURB NTS

Pavement Engineering Inc.
 You can ride on our reputation
 Corporate Office:
 3485 Sacramento Drive, Suite A
 San Luis Obispo, CA 93401
 805.781.2265



EAST SIDE UNION HIGH SCHOOL DISTRICT
 INDEPENDENCE HIGH SCHOOL
 617 NORTH JACKSON AVENUE, SAN JOSE, CA
 SPECIAL SERVICES GROWTH & SUPPORT CENTER
 DETAILS

DRAWN BY:	JT
PROJECT NUMBER:	260061-01
SCALE:	NTS
VERIFY SCALE	
BAR REPRESENTS	1\"/>
DATE:	APRIL 2026
SHEET NUMBER:	

P:\R\2\SHARED\DRIVE\PROJECTS\EAST SIDE\INDEPENDENCE HIGH\BUS TURNOUT\TASK 01 - DESIGN\DRAWINGS\260061-01_INDEPENDENCE HIGH SCHOOL\BUS TURNOUT.DWG Plot Date: 4/21/2026 11:29 AM

EAST SIDE UNION HIGH SCHOOL DISTRICT
INDEPENDENCE HIGH SCHOOL (BUS TURNOUT)
SAN JOSE, CALIFORNIA
TECHNICAL SPECIFICATIONS

Table of Contents

00 00 00	Table of Contents
02 41 13	Site Demolition
02 41 15	Site Utility Repair
03 30 53	Sitework Concrete
03 90 05	Concrete Joint Sealant
22 14 00	Storm Drainage
31 23 00	Excavation, Grading & Backfill
31 32 13.19	Lime Soil Stabilization
32 00 01	General Exterior Site Construction Requirements
32 01 26.71	Cold Planing
32 01 90.24	Root Pruning
32 11 23	Aggregate Base
32 12 16	HMA Paving
32 12 16.05	HMA Pavement Repairs
32 17 23	Pavement Markings
32 31 13	Chain Link Fencing
32 84 21	Utility Sleeves
32 84 23	Underground Irrigation System
32 91 13	Soil Preparation
32 93 00	General Planting Requirements
32 93 15	Landscape Restoration
32 93 23	Lawn Sodding

SECTION 02 41 13
SITE DEMOLITION

PART 1 GENERAL

1.1 SUMMARY

- A. Includes But Not Limited To:
 - 1. Demolish and remove portions of existing site facilities as described in Contract Documents.
- B. Related Sections:
 - 1. Section 32 00 01 - General Exterior Site Construction Requirements
 - 2. New and replacement work specified in appropriate specification Section.

1.2 PRICE AND PAYMENT PROCEDURES

- A. If the project contains a Lump Sum price for demolition, all demolition activities shall be included under that bid price and not individual remove and replace items.
- B. If the project contains Unit Prices for various items such as "Remove Roots Under Repairs"; the cost of removal shall be included in the item of work.
- C. If the project is bid as a lump sum, no additional payment will be made for site demolition work.

1.3 ADMINISTRATIVE REQUIREMENTS

- A. Coordination
 - 1. **Contractor shall contact an Underground Service Alert entity forty-eight (48) hours in advance of work, and have all utilities marked prior to the preconstruction meeting or ground disturbance.**
 - 2. Contractor shall request access to Owner's water service controls.
 - 3. Contractor shall coordinate with affected utilities, transportation agencies, schools, waste disposal companies, and any other pavement users.
 - 4. Contractor shall coordinate with other contractors working on the site.
 - 5. Contractor shall use approved trucking routes from the Owner on Project haul routes.
- B. Preconstruction Meeting
 - 1. Contractor shall schedule a preconstruction meeting prior to initiating work.
 - 2. Attendees at the preconstruction meeting shall include but not be limited to:
 - a. Owner's Representative
 - b. Contractor's **Project Manager and General Superintendent**
 - c. **Subcontractor Representatives** (if applicable)
 - d. QA Representative
 - e. QC Representative
 - f. Other pavement users or affected parties as applicable.
- C. Sequencing
 - 1. Contractor shall sequence the work to minimize disruption to existing project users.
 - 2. Contractor shall sequence the work to prevent demolition operations from damaging new and existing sitework features.
 - 3. Contractor shall not commence demolition until all Storm Water Protection BMPs have been installed.

- D. Scheduling
 - 1. Construction Schedule shall include a detailed sequence of individual site demolition operations.
 - 2. Contractor shall coordinate with Owner for equipment and materials to be removed by Owner, if necessary.

1.4 SUBMITTALS

- A. Upon Project Closeout, Contractor shall Identify abandoned utility and service lines and capping locations on record drawings.

1.5 CLOSEOUT SUBMITTALS

- A. Owner shall be provided with documentation of disposal and recycling of site demolition material.

PART 2 PRODUCTS - Not Used

PART 3 EXECUTION

3.1 EXAMINATION

- A. Contractor shall examine site to determine extent of work necessary to separate work to be removed from work to remain. If separation procedure is unclear, Contractor shall request clarification from Owner's Representative at least five (5) working days in advance of demolition.

3.2 PREPARATION

- A. Contractor shall notify corporations, companies, individuals, and local authorities owning conduits running to property.
 - 1. Conduits, drains, sewers, pipes, and wires that are to remain on the property shall be protected and maintained.
 - 2. Contractor shall arrange for removal of wires running to and on property and remove pipes and sewers in accordance with instructions of Owners.
 - 3. Locations of all underground utilities encountered including abandoned, damaged, repaired or unknown facilities shall be marked on record drawings.
- B. Contractor shall be responsible for protecting soil stability underlying facilities during demolition.
- C. Contractor shall be responsible for protecting existing facilities.

3.3 PERFORMANCE

- A. Work shall be executed in an orderly and careful manner, with due consideration for neighbors and the public. **Contractor shall control dust.**
- B. Existing items shall be carefully removed, disassembled, or dismantled as required, and stored in an approved location on site. Existing items shall be reused in completed work.
- C. Concrete and Paving Removal
 - 1. Full depth saw cut joints between material shall be removed and material shall remain.
 - 2. Existing concrete site elements or pavement damaged during demolition or work shall

be resawcut and replaced at Contractor's expense.

D. Site Clearing

1. Tree and Brush Removal

- a. Trees, shrubs, brush and vegetative growth shall be cut 12 inches maximum above ground.
- b. Stumps and roots shall be removed 12 inches below original ground surface or until stump and all roots 1 inch or larger are removed.
- c. Roots of plants that normally sprout from roots shall be entirely removed as identified by Owner's Representative.

2. Root Pruning and Removal

- a. Trench shall be hand excavated 1 foot wide and 20 inches deep along concrete or paving to be removed.
- b. Roots encountered shall be cut with saw, axe, or pruners. Roots with excavating equipment.
- c. Roots under concrete and paving shall be removed to 12 inches below top of base or native subgrade.

3. Stripping

- a. Existing vegetation layer shall be stripped 2 inches and removed from site prior to stripping topsoil for storage and reuse if necessary.
- b. After stripping existing vegetation layer, existing topsoil shall be stripped an additional 4 inches and stored onsite for reuse if necessary.

E. Excavation

1. Contractor shall use excavation equipment and methods that do not cause or increase subgrade instability.
2. Contractor shall use methods that preclude tracking of soils or debris off site or onto streets, etc.

F. Disposal

1. all trees, shrubs, stumps, vegetative layer, asphalt concrete, removed concrete site elements and surface debris shall be immediately removed from site.
2. Waste shall not be buried or burned.
3. Work shall comply with all local, state, and federal disposal and recycling regulations.
4. If hazardous materials are encountered, Contractor shall refer to the General Conditions.

G. Site Maintenance

1. Contractor shall broom clean all remaining surfaces immediately after demolition and removal of debris. Contractor shall maintain broom clean condition.
2. Contractor shall maintain all storm water protection measures.
3. Contractor shall provide continuous dust control measures until work is complete.

END OF SECTION

SECTION 02 41 15
SITE UTILITY REPAIR

PART 1 GENERAL

1.1 SUMMARY

- A. Work Shall Include but Not be Limited to the Following:
1. Location of existing utilities for the site shall be identified using existing plans, obvious surface features, locations of facilities, locator services, and other practical means **forty-eight (48) hours prior to ground disturbance.**
 2. Locations where identified site utilities may conflict with the planned construction shall be potholed five (5) days in advance of the work to ascertain if a conflict exists. If a conflict does exist, Owner's Representative shall be notified immediately.
 3. Contractor shall repair existing utilities damaged during construction.

1.2 PRICE AND PAYMENT PROCEDURES

- A. Payment for Repairs
1. A Utility Repair Allowance will be included in the project Bid Schedule. Contractor shall include this amount in their total bid.
 2. Payment for site utility repairs will be made as follows:
 - a. Damage due to Contractor's error or negligence shall be paid by Contractor
 - b. Damage due to unidentifiable or unknown conditions will be paid through Site Utility Repair Allowance.
 - 1) Subcontractor markup shall be limited to five percent (5%)
 - 2) Own forces markup will be fifteen percent (15%)
 - 3) **"Greenbook" and Cal Trans Force Account rules shall not apply to this Project. Only equipment, material, and personnel directly associated with repair will be considered "extra work" by Owner.**
 - 4) There will be no compensation for delays related to site utility repairs.
- B. At the completion of the work, remaining monies in the Site Utility Repair Allowance will be credited back to Owner by a change order.

1.3 ADMINISTRATIVE REQUIREMENTS

- A. Coordination
1. Contractor shall coordinate with affected utilities.
 2. Contractor shall coordinate with other contractors working on the site.
 3. Contractor shall coordinate with site landscape maintenance company.
- B. Preconstruction Meeting
1. Contractor shall schedule a preconstruction meeting prior to initiating work.
 2. Attendees at the preconstruction meeting shall include but not be limited to:
 - a. Owner's Representative
 - b. Contractor's **General Foreman**
 - c. Subcontractors (if applicable)
 - d. QA Representative
 - e. QC Representative
 - f. Other site users or affected parties as applicable.
- C. Scheduling
1. Contractor shall include locating underground facilities as an initial scheduled activity.
 2. Contractor shall perform potholing of potential conflicting utilities within forty-eight (48) hours after the conflict is identified.

1.4 SUBMITTALS

- A. Contractor or subcontractors to perform the repairs shall be identified prior to the initiation of work, and telephone number shall be made available to the Owner's Representative.
 - 1. Contractor shall have the resources available to immediately and expeditiously repair damaged utilities, without impact to the schedule, including:
 - a. site lighting
 - b. irrigation lines and wires
 - c. water services
 - d. electrical lines

1.5 CLOSEOUT SUBMITTALS

- A. Contractor shall provide Owner with record drawings indicating site utility repairs with related information including photographs.

PRODUCTS

1.6 MATERIALS

- A. Materials used for repairs shall be compatible and similar to the site utility to be repaired.
- B. Minimum thickness of plastic pipe for irrigation repairs shall be Schedule 40.
- C. Utility Boxes: Traffic-rated boxes and lids in pavement areas shall be plastic or composite boxes in landscape areas.
- D. Wire Connectors: 3M AY type connectors shall be used for wire splices.

PART 2 EXECUTION

2.1 PROTECTION

- A. Contractor shall be responsible for protecting existing site utilities identified or that should have been identified by compliance with these Specifications.

2.2 CONSTRUCTION

- A. Contractor shall be responsible for repairing damaged lines or wiring caused by the Contractor's failure to adequately identify or protect existing utility lines.
- B. Contractor shall repair damaged utilities that were not able to be identified or protected.
 - 1. Contractor shall make all repairs in accordance with the applicable codes. Care shall be exercised to avoid further damage to existing facilities during repairs.
 - 2. The repaired lines or wiring shall be tested prior to backfilling.
 - 3. Contractor shall be responsible for any damage to the completed work due to improper repairs of existing site utilities.
 - 4. Electrical splices:
 - a. Contractor shall replace damaged electrical lines from existing pull boxes or facilities. Splices shall only be made with the express permission of the Owner.
 - b. Damaged irrigation wiring may be spliced with wire connectors. Splices in wiring run shall have a utility box placed over the splice.

END OF SECTION

SECTION 03 30 53
SITWORK CONCRETE

PART 1 GENERAL

1.1 SUMMARY

- A. Work Shall Include but Not be Limited to the Following:
 - 1. Contractor shall remove existing concrete and related materials.
 - 2. Subgrade for cast-in-place concrete site elements shall be compacted as described in Contract Documents.
 - 3. Granular base for cast-in-place concrete site elements shall be furnished and installed as described in Contract Documents.
 - 4. Cast-in-place concrete site elements shall be furnished and installed as described in Contract Documents.

- B. Related Sections
 - 1. Section 02 41 13 - Site Demolition
 - 2. Section 03 90 05 - Concrete Joint Sealant
 - 3. Section 31 23 00 - Excavation, Grading & Backfill
 - 4. Section 32 00 01 - General Exterior Site Construction Requirements

1.2 PRICE AND PAYMENT PROCEDURES

- A. Detectable Warning Surface will be measured and paid for on a square foot basis as listed in the Bid Schedule.

- B. Stair Treads will be included in the bid price for stair construction and no separate payment will be made, therefor.

- C. Concrete Joint Sealant will be included in the various items of work.

- D. All other items of site work concrete will be measured and paid for as listed in the Bid Schedule and will be considered full compensation for all labor, equipment, and materials required to perform the work as described herein.

- E. If sample panel(s) is/are required, it/they will be included in the unit cost of the work.

1.3 REFERENCES

- A. American Society for Testing and Materials (Most recent version)
 - 1. ASTM D 1751, 'Standard Specification for Preformed Expansion Joint Filler for Concrete Paving and Structural Construction (Non-extruding and Resilient Bituminous Types)'
 - 2. ASTM A 615, 'Standard Specification for Deformed and Plain Billet-Steel Bars for Concrete Reinforcement'
 - 3. ASTM C 33, 'Standard Specifications for Concrete Aggregates'
 - 4. ASTM C 94, 'Standard Specifications for Ready-Mixed Concrete'
 - 5. ASTM C 150, "Standard Specifications for Portland Cement"

- B. 2018 Caltrans Standard Specifications immediately connected to concrete work

- C. California Building Code. (most recent version)

- D. Americans Disabilities Act including most recent rulings
- E. Applicable Caltrans Standard Details if applicable to the work (either because within Caltrans Right of Way or by municipal reference)

1.4 DELIVERY, STORAGE, AND HANDLING

- A. Reinforcing steel shall be free of mud, heavy rust scales or flakes, or other coating at time of delivery and placement. Rebar shall be properly protected on site after delivery.

1.5 SUBMITTALS

- A. Concrete Mix Designs
- B. Aggregate Base
- C. Safety Treads
- D. Detectable Warning Surface
- E. Concrete Joint Primer and Sealant
- F. Concrete Color
- G. Concrete Stamp Patterns

1.6 ACTION SUBMITTALS

- A. Delivery Tickets - Mix plant shall furnish delivery ticket for each batch of concrete. Contractor shall keep delivery tickets at job site for use of Owner's Representative. Tickets shall show the following:
 - 1. Name of ready-mix plant
 - 2. Serial number of ticket
 - 3. Date and truck number
 - 4. Name of Contractor
 - 5. Name and location of Project
 - 6. Specific class or designation of concrete in conformance with the specifications. Class or designation shall match mix approved mix design.
 - 7. Amount of concrete
 - 8. Time loaded
 - 9. Type, name, and amount of admixtures used.
 - 10. Amount and type of cement
 - 11. Total water content
 - 12. Sizes and weights of sand and aggregate
 - 13. Fiber additive

1.7 QUALITY ASSURANCE

- A. Quality Assurance (QA) Inspection and/or Testing.
 - 1. Owner may, at their option, have independent quality assurance inspection and testing.
 - a. Inspections may be made during or after the work.
 - b. QA Inspection and testing shall be for the sole purpose of providing the Owner a greater degree of assurance that the requirements of the contract have been met. QA inspection and testing shall not relieve the Contractor of any

- responsibility to comply with or perform in accordance with the Contract documents.
2. All QA concrete testing laboratories shall be CCRL, ACI, or otherwise qualified under ASTM C1077-14.
- B. Notification Required – **Contractor shall allow Owner’s Representative to verify grades and elevations or to schedule QA personnel. Contractor shall notify Owner’s Representative forty-eight (48) hours minimum prior to placing concrete.**

PART 2 PRODUCTS

2.1 MATERIALS

- A. Formwork
 1. Material: Wood, metal or plastic
 2. Size
 - a. Straight Runs – 2-inch nominal thickness minimum.
 - b. Curves - laminated to 3/4-inch thickness minimum.
 - c. Depth - Within 2 inches of specified depth.
 3. Staking - 2 foot maximum spacing.
- B. Aggregate Base -
 1. 3/4-inch Class 2 Aggregate per Section 26 of Caltrans Standard Specifications.
 2. Onsite Recycled Base per Section 32 12 16.
 3. Grindings from cold planing less than 2 inches in maximum dimension.
- C. Expansion Joints
 1. Manufactured commercial fiber type meeting requirements of ASTM D 1751 and 1/2 inch thick.
- D. Concrete Reinforcing Steel
 1. Grade 40 deformed bars.
- E. Concrete
 1. Type I/II Cement
 2. All concrete except swales and PCC pads for dumpsters:
 - a. 1-inch maximum aggregate size.
 - b. 5 sack minimum.
 - c. 2,500 psi in twenty-eight (28) days.
 - d. 4-inch maximum slump.
 - e. Fibermesh Polypropylene Fibers, or equivalent, 3/4 inch minimum length @ 1.5 lbs/cy (0.01% by volume).
 3. Concrete swales and PCC pads for dumpsters:
 - a. 1 inch maximum aggregate size.
 - b. 6 sack minimum.
 - c. 2,000 psi in seven (7) days.
 - d. 3,500 psi in twenty-eight (28) days.
 - e. 4-inch maximum slump.
 - f. Fibermesh Polypropylene Fibers, or equivalent, 3/4 inch minimum length @ 3.0 lbs/cy (0.02% by volume).
 4. Omit Fibermesh on colored and/or textured concrete.
- F. Safety Treads - Wooster Products Inc. Type 231 complying with latest addition of CBC for placement and color.
 1. Warning strip on top and bottom steps shall differ in color from intermediate stair

treads.

- G. Detectable Warning Surface -
 - 1. Tactile warning dots per Section 1133B.8.5 of the of the California Building Code.
 - a. 36 inch minimum width.
 - b. Durable, slip-resistant material with a surface texture composed of raised, truncated domes in a staggered pattern with a diameter of nominal 0.9 inch at the base tapering to 0.45 inch at the top, a height of nominal 0.2 inch, and a center spacing of nominal 2.35 inch.
 - c. Color as specified on Plans. If no color is specified, color shall be Safety Yellow.
 - d. "Set-in-concrete" system required (No glued & screwed mat systems installed after finished concrete)
 - 2. Acceptable Products (in safety yellow color):
 - a. "Wet-Anchor Box" by Disability Devices, Inc.
http://www.disabilitydevices.com/Offset_Dome_Tactile_Warning_Mat.html
 - b. "Cast-in-Place System" by Armor-Tile.
<http://www.armor-tile.com/truncateddomes/surface-applied-systems.htm>
 - c. Approved equal by Owner's Representative prior to bidding.
- H. Concrete Joint Sealant
 - 1. Pourthane SL Product 773-A by W. R. Meadows/SealTight
 - 2. Sikaflex Self-Leveling Sealant
 - 3. Or equal

PART 3 EXECUTION

3.1 PREPARATION

- A. Survey and stake site work concrete shall indicate locations and elevations required by the Contract Documents. **Notification to Owner's Representative of grades set by Contractor Required – Contractor shall allow Owner's Representative to verify grades and elevations forty-eight (48) hours minimum prior to placing concrete.**
- B. Subgrade
 - 1. Elevations shall be fine graded required by Contract Documents with allowances for required concrete and aggregate base thickness.
 - 2. Native soils shall be compacted to ninety percent (90%) relative compaction at optimum moisture of plus or minus two percent (+/- 2%).
- C. Aggregate Base
 - 1. Where required, Contractor shall place required thickness.
 - 2. Elevations shall be fine graded required by Contract Documents with allowances for required concrete and aggregate base thickness.
 - 3. Compaction shall be to ninety percent (90%) relative compaction at optimum moisture +/- 2 percent.
- D. Sidewalk sample for specified finishes (not including broom-finished concrete)
 - 1. Prior to placing any concrete for sidewalks, Contractor shall prepare a 4-foot by 4-foot sample with the specified finish(s) for approval by the Owner's Representative.
 - a. Approved sample shall remain on-site for the duration of the concrete work and shall be disposed of at the completion of the final concrete pour.
 - b. Approved sample work shall not be a part of the finished work product.
- E. Protection of Existing Facilities

1. All vertical surfaces within ten (10) feet of the work shall be covered to a height of 3 feet with sheet plastic
2. Existing hardscape surfaces shall be protected with tape and plastic sheeting.
3. Any damage to adjacent finishes shall be repaired to the satisfaction of the existing facility owner. Repainting shall extend across the entire plane from corner to corner.
4. Horizontal surfaces shall be protected from graffiti or other damage.

3.2 INSTALLATION

A. Site Tolerances

1. Vertical
 - a. Subgrade - 0.00 feet high.
 - b. Aggregate Base - 0.00 feet high.
 - c. Finish Concrete +/- 0.02 feet.
2. Horizontal
 - a. General Finish Concrete - +/- 0.10 feet.
 - b. Required Widths - 0.00 to +0.10 feet.
3. Layout
 - a. Horizontal dimensions shall be within +/- 0.10 feet.
4. Exterior Accessible Travel Paths
 - a. Landings, Ramps, Crosswalks, Sidewalks, and other Pedestrian Travel Paths
Cross slopes - two percent (2%) or less.
 - b. Sidewalks - five percent (5%) or less longitudinal slope.
 - c. Ramps - 8.33 percent or less longitudinal slope.
 - d. Maximum vertical distance between landings - 30 inches.
5. Variations in stairs
 - a. Consecutive steps-
 - 1) Treads -1/4 inch, 11-inch minimum width.
 - 2) Risers - 1/4 inch, 4 inch-minimum, 7-inch maximum.
 - b. Flight of stairs -
 - 1) Treads -3/8 inch.
 - 2) Risers - 3/8 inch.
6. Landings at Doorways -
 - a. 1/4-inch maximum differential between top of threshold and surface of landing.
7. Forms
 - a. Vertical surfaces shall be formed to be within 2 inches of subgrade.
 - b. Gaps between forms shall not exceed 1/4 inch.

B. Joints

1. Joints of sidewalks, curbs, and gutters shall be aligned.
2. Expansion Joints with joint material -
 - a. Spacing -
 - 1) Sidewalks, Curbs, and Curb & Gutters - 50 feet on-center.
 - 2) Mow Strips - 10 feet on-center.
 - 3) Flat Drainage Structures - 50 feet on-center.
 - 4) Retaining Walls - 36 feet on-center.
 - b. Full depth of sidewalk, curbs, gutters, pads, etc.
 - c. If reinforcement is required, rebar shall extend through expansion joint material.
 - d. Shall be placed at corner of curb and curb & gutter.
 - e. Shall be installed so top of expansion joint material is 1/4 inch below finished concrete surface.
 - f. No expansion joint shall be required between curbs and walks parallel to curb.
 - g. Contractor shall provide expansion joint at end of walks perpendicular to and terminating at curb.
 - h. Contractor shall provide expansion joint between concrete work and buildings.

Expansion joint shall be 1/2 inch below finished concrete surface. Caulk shall be per Section 30 90 05.

3. Contraction Joint Spacing -
 - 1) Sidewalks, Curbs, and Curb & Gutter - 10 feet on-center.
 - 2) Mechanical Pads, Dumpster Enclosures, etc. - 12 feet on-center.
 - 3) Flat Drainage Structures - 10 feet on-center.
- b. Contraction Joint Depth
 - 1) 1-inch minimum depth.
 - 2) 1/4 to 1/3 concrete thickness.
- c. Location
 - 1) Contractor shall align sidewalk and curb and/or gutter.
 - 2) If placing on existing concrete, Contractor shall align with underlying contraction joints and cracks if feasible.
 - 3) Contractor shall place at all inside corners.
 - 4) At square utility boxes, Contractor shall place contraction joints at each corner.
 - 5) At round utility boxes, Contractor shall place joint through center to nearest edges of concrete.
 - 6) Spacing may be increased or decreased to 12 feet to accommodate utility boxes.
- d. Type
 - 1) Tooled joint up to 6 inch concrete depth. Tooled joints shall be required for all sidewalks. Sawcuts shall be not allowed. Tooled joint may be deepened with sawcut within twenty-four (24) hours of concrete placement if necessary.
 - 2) Sawcut or parting strip for concrete depths over 6 inches. All sawcuts shall be made within twenty-four (24) hours of concrete placement.
4. Inserts, Stair Treads, etc. – Contractor shall precut and place prior to concrete placement where practical.
5. Crack Repair - Cracks resulting from failure to comply with requirements shall require removal and replacement of entire panel or section of concrete to adjacent contraction joints.

C. Finish

1. Curb, Gutter, Slabs, Mow Strips, Flat Drainage Structures, And Miscellaneous
 - a. Light Broom finish.
 - b. Round edges including edges formed by expansion joints.
 - c. Remove edger marks.
2. Sidewalk – Unless specified otherwise on Plans, sidewalks shall have a light broom finish with the following requirements:
 - a. Washed, Fine Aggregate surface (3/8 inch max. size aggregate).
 - b. Round edges including edges formed by expansion joints.
 - c. Contractor shall remove edger marks.
3. Curb Faces -
 - a. Contractor shall remove forms as soon as practical.
 - b. Contractor shall fill voids with fresh concrete if necessary.
 - c. Contractor shall finish face full depth with smooth steel trowel finish.
 - d. Contractor shall remove any excess concrete beyond form line at bottom of curb face at time of finishing.
4. Walls -
 - a. Immediately after removing forms, Contractor shall remove joints, marks, bellies, projections, loose materials, and cut back metal ties from surfaces to be exposed.
 - b. Contractor shall point up voids with cement mortar, 1:2 mix, and rub exposed surface with carborundum to smooth, even surface.
5. Ramps -

- a. Contractor shall medium broom finish transverse to direction of travel on ramp.
- D. Special Requirements
- 1. Contractor shall form vertical surfaces full-depth and shall not allow concrete to flow out from under forms in any degree. Contractor shall remove any excess concrete beyond form face immediately after forms removed.
 - 2. Sidewalks, Exterior Stairs, And Landings -
 - a. Slope to drain.
 - 1) Contractor shall slope sidewalks with cross slope of one percent (1%) minimum to two percent (2%) maximum in direction of intended drainage.
 - 2) Contractor shall slope sidewalks away from building one percent (1%) minimum.
 - b. Dusting with cement shall not be permitted.
 - c. Adding water during finish shall not be permitted.
 - 3. At Channel Iron over Rainleaders -
 - a. Contractor shall grout space between pipe and channel iron at curb face and sidewalk edge.
 - b. Contractor shall grind 1/4-inch bevel on sawcut edge if applicable prior to concrete placement, and round over concrete edge of fresh concrete.
 - 4. Light Pole Bases
- E. Detectable Warning Surfaces -
- 1. Layout -
 - a. 36-inch minimum width, length per plan.
 - b. Surface flush with adjacent concrete.
 - 2. Contractor shall install warning surface in accordance with manufacturer's recommendations.
- F. Concrete Joint Sealant
- 1. Cleaning
 - a. Contractor shall remove all contaminants, including dirt, paint, curing compounds, grease, oil, or other non-compatible substances or compounds.
 - b. Contractor shall not use any oil-based cleaning compounds.
 - c. After cleaning, Contractor shall vacuum thoroughly.
 - 2. Sealant
 - a. Contractor shall cure new concrete a minimum of twenty-eight (28) days prior to sealing.
 - b. Application
 - 1) Surface of sealant shall be 1/16 inch to 3/16 inch below the concrete surface.
 - 2) Contractor shall clean all sealant off adjacent concrete surfaces.
 - c. Protection
 - 1) Contractor shall protect sealed joints until sealant is fully set.

3.3 FIELD QUALITY CONTROL

- A. Formwork Dimensions and Grades
 - 1. Contractor shall verify that the formwork conforms to the required dimensions and elevations prior to placement of concrete.
- B. Contractor shall verify ADA travel path slopes and cross slopes, and shall check the following:
 - 1. formwork prior to concrete placement
 - 2. placed concrete during finishing
 - 3. completed work prior to placing curing compound

C. Concrete Drainage Structures

1. Contractor shall water test flowlines of drainage structures such as gutters, swales, and v-ditches during the finishing process to eliminate high or low areas and any areas of ponding.

END OF SECTION

SECTION 03 90 05
CONCRETE JOINT SEALANT

PART 1 GENERAL

1.1 SUMMARY

- A. Work Shall Include but Not be Limited to the Following:
 - 1. Installation of joint sealant in concrete sidewalks.
- B. Related Sections
 - 1. Section 32 00 01 - General Exterior Sitework Requirements

1.2 SUBMITTALS

- A. Joint Sealant Primer
- B. Joint Sealant

PART 2 PRODUCTS

2.1 MATERIALS

- A. Joint Sealant Primer
 - 1. Burke 3203 U-Seal Primer, or approved equal.
- B. Joint Sealant
 - 1. Burke by Edoco U-Seal Joint Sealant 3201, or approved equal.

PART 3 EXECUTION

3.1 INSTALLATION

- A. Cleaning
 - 1. Contractor shall remove all contaminants including dirt, paint, curing compounds, grease, oil or other non-compatible substances or compounds.
 - 2. Contractor shall not use any oil-based cleaning compounds.
 - 3. After cleaning, Contractor shall vacuum thoroughly.
- B. Priming
 - 1. Contractor shall allow all cleaned surfaces to dry thoroughly.
 - 2. Contractor shall prime all surfaces to be sealed.
 - 3. Contractor shall allow primer to cure until tack-free, allow two (2) hours minimum drying time.
 - 4. Contractor shall apply in accordance with manufacturer's recommendations.
 - 5. Temperature
 - a. Concrete surface and atmospheric temperatures shall be 50 degrees Fahrenheit and rising.
 - b. At the time of mixing, product temperature shall be between 65 and 85 degrees Fahrenheit.

- C. Sealant
 - 1. Contractor shall new concrete to cure a minimum of twenty-eight (28) days prior to sealing.
 - 2. Mixing
 - a. Contractor shall not open container until ready to use.
 - b. Temperature of both parts at the time of mixing shall be between 65 and 85 degrees Fahrenheit.
 - c. Contractor shall mix in accordance with manufacturer's recommendations.
 - 3. Application
 - a. Surface of sealant shall be 1/16" to 3/16" below the concrete surface.
 - b. Contractor shall clean all sealant off adjacent concrete surfaces.
 - 4. Protection
 - a. Contractor shall protect sealed joints until sealant is fully set.

PART 4 PAYMENT

- A. Payment for all work associated with concrete joint sealant will be included in the various items of work and no separate or additional compensation shall be allowed, therefor. Said payment will be considered full compensation for furnishing all labor, materials, tools, equipment, and incidentals, and for doing all the work described herein.

END OF SECTION

SECTION 22 14 00

STORM DRAINAGE

PART 1 GENERAL

1.1 SUMMARY

- A. Work Shall Include but Not be Limited to the Following:
 - 1. Contractor shall perform excavating and backfilling required for work of this Section.
 - 2. Contractor shall furnish and install storm drainage system as described in Contract Documents.
 - 3. Contractor shall connect to existing facilities
 - 4. Contractor shall clean out existing pipes and structures, including through curb drains.
- B. Related Sections
 - 1. Section 32 00 01 - General Exterior Site Construction Requirements

1.2 REFERENCES

- A. American Association Of State Highway And Transportation Officials
 - 1. AASHTO M-252, 4 to 10-inch pipe, 'Specifications for Corrugated Polyethylene Pipe'
 - 2. AASHTO M-294, 12 to 36-inch pipe, 'Specifications for Corrugated Polyethylene Pipe'
- B. American Society For Testing And Materials (most recent revisions)
 - 1. ASTM A 74, 'Standard Specification for Cast Iron Soil Pipe and Fittings'
 - 2. ASTM A 929, 'Standard Specification for Steel Sheet, Metallic-Coated by the Hot-Dip Process for Corrugated Steel Pipe.'
 - 3. ASTM C 14, 'Standard Specification for Concrete Sewer, Storm Drain, and Culvert Pipe'
 - 4. ASTM C 76, 'Standard Specification for Reinforced Concrete Culvert, Storm Drain, and Sewer Pipe'
 - 5. ASTM C 564, 'Standard Specification for Rubber Gaskets for Cast Iron Soil Pipe and Fittings'
 - 6. ASTM D 2321, 'Standard Practice for Underground Installation of Thermoplastic Pipe for Sewers and Other Gravity-Flow Applications'
 - 7. ASTM D 3034, 'Standard Specification for Type PSM Poly (Vinyl Chloride) (PVC) Sewer Pipe and Fittings'

PART 2 PRODUCTS

2.1 MATERIAL

- A. Bedding Material - Clean fill sand
- B. Backfill
 - 1. CLSM
 - 2. Slurry Cement Backfill per Section 19-3.062, Caltrans Standard Specifications.
 - 3. 3/4 inch Class 2 Aggregate Base per Section 26, Caltrans Standard Specifications.

2.2 COMPONENTS

- A. Catch Basins & Area Drains - Paving and Landscape Areas
 - 1. Precast Structures as shown on Plans.

2. Contractor shall include cover inlet with cast iron frame and grate as shown on Plans.
 3. Cast-in-place Bases
 - a. 4000 psi concrete
 - b. 6-inch minimum thickness
 - c. Base shall be extended 6 inches beyond wall of structure.
 4. Frame and Grate as shown on Plans.
 - a. Traffic Areas shall be heavy duty and traffic rated.
 - b. Frames in concrete aprons or swales shall be cast into concrete with paving notch type frame.
 - c. All grates shall have bicycle bars and be bolted to frames.
 5. Approved Manufacturers
 - a. Associated Concrete Products (925) 426-1100
 - b. Christy Concrete Products (800) 287-4788
 - c. Central Precast Products (800) 500-5016
 - d. Approved Equal by Owner
- B. Area Drains - Sidewalk and Other Concrete Pedestrian Areas
1. Cast Iron Drain Inlets with Bronze Grates and elastomeric seals.
 2. Approved Manufactures
 - a. Zurn Industries (877) 875-1404.
 - b. Approved Equal by Owner.
- C. Concrete Pipe
1. Non-Reinforced - Shall meet requirements of ASTM C 14.
 2. Reinforced -
 - a. Shall meet requirements of ASTM C 76, plain end.
 - b. Contractor shall determine class of pipe by depth of cover over pipe at rough-graded elevations as follows -

Depth Of Cover	Class Of Pipe
Under 2 feet	V
2 feet to 3 feet	IV
3 feet to 6 feet	III
Over 6 feet	II
- D. PVC Pipe and Fittings
1. Meet requirements of ASTM D 3034, SDR 35
 2. Fittings - Slip Joint type with elastomeric seals.
- E. Corrugated Polyethylene Pipe and Fittings
1. Shall meet requirements of AASHTO M-252 or M-294, Type S.
 - a. Corrugated, helical, or annular exterior with smooth interior and gasketed connectors.
 - b. Hancor Hi-Q, ADS N-12, or equal approved by Owner
- F. Cast Iron Soil Pipe and Fittings
1. Shall meet requirements of ASTM A 74.
 2. Joint Material -
 - a. Rubber gaskets shall meet requirements of ASTM C 564 and compatible with pipe used.
- G. Fittings - All Pipe Types where applicable
1. Contractor shall use only Wyes. Tees shall not be allowed
 2. Contractor shall use 1/8 bends or less or combination thereof for direction changes. Contractor shall not use 90 degree ells. Long sweep cast iron fittings shall be allowed.

- H. Cleanouts
 - 1. Christy Concrete Products (800) 287-4788
 - 2. Approved Equal by Owner.

- I. Cleanouts in Sidewalk or Other Pedestrian Areas
 - 1. Zurn Industries (877) 875-1404.
 - 2. Approved Equal by Owner.

- J. Manholes
 - 1. Precast Manholes with concrete risers as necessary.
 - a. 48-inch eccentric manholes with either cone or flat top transition to 24-inch round riser rings.
 - b. Steps required.
 - c. Approved Manufacturers
 - 1) Associated Concrete Products (925) 426-1100
 - 2) Central Cast Products (800) 500-5016
 - 3) Approved Equal by Owner.
 - d. Cast-in-place Bases
 - 1) 4000 psi concrete
 - 2) Use forming ring to create match for precast barrel sections.
 - 3) 6-inch minimum thickness.
 - 4) Contractor shall extend base 6 inches beyond outside of precast barrel.
 - 2. Frames and Covers
 - a. South Bay Foundry SBF 1900-Reg
 - b. D&L Foundry A-1024
 - c. Stamped "Storm Drain" on Cover.
 - d. Approved Equal by Owner.

PART 3 EXECUTION

3.1 PREPARATION

- A. Storage
 - 1. Contractor shall store pipe and fittings where protected from damage and on flat surface to prevent bending of pipe.
 - 2. Contractor shall protect elastomeric seals from sunlight damage.
 - 3. Contractor shall not drop, throw, or drag pipe, fittings, or structures.
 - 4. Damage pipe, fittings or structures shall be replaced.
 - 5. Contractor shall not block emergency access or facilities

3.2 INSTALLATION

- A. Pipe Installation
 - 1. Contractor shall excavate trench a minimum of 6 inches wider than the outside diameter of the pipe.
 - 2. Runs shall be as close as possible to those shown on Plans
 - 3. Contractor shall excavate to required depth and grade from downstream end up slope.
 - 4. Contractor shall provide shoring as required by
 - a. Cal OSHA
 - b. CalTrans Specifications, Sections 5-1.02A and 7.1.01E
 - c. Local agency requirements
 - 5. Contractor shall remove debris from trench prior to laying of bedding and pipe.
 - 6. Contractor shall backfill over excavated trench bottoms in excess of 2 inches with native soils compacted to ninety percent (90%) relative compaction.

7. Contractor shall not cut trenches near footings without consulting Owner.
8. Contractor shall lay pipes with bells on the upstream end of pipe, and excavate bell hole as required. Contractor shall make joints in accordance with manufacturer's recommendations.
9. Contractor shall secure pipe from floating during backfill and maintain 2 inches minimum clearance from trench wall to pipe.
10. Pipes shall be within **0.03** foot of design grades when backfilled and shall be free of dips or humps.
11. Contractor shall backfill only after pipe lines have been tested, inspected, and approved by Owner.
12. Contractor shall backfill with either CLSM or Cement Slurry as soon as practical after placement of pipe.
 - a. In landscape areas, Contractor shall place backfill to within 12 inches of surface. Contractor shall backfill remaining trench with topsoil compacted to eighty-five percent (85%) relative compaction.
 - b. Under concrete, Contractor shall extend backfill to top of native material.
 - c. In existing pavement areas, Contractor shall extend backfill to top of aggregate base.
 - d. In new pavement areas, Contractor shall extend backfill to top of native soils.
13. Special Pipe Installation Requirements
 - a. Concrete Pipe
 - 1) Contractor shall provide 3 inches of compacted sand bedding material below pipe.
 - 2) After installation of pipe, Contractor shall provide additional sand bedding material up to spring line of pipe.
 - b. PVC / Polyethylene Pipe
 - 1) Contractor shall Install in accordance with ASTM D 2321.
 - 2) Minimum cover for corrugated polyethylene pipe and fittings shall be 12 inches for H-20 load.

B. Structure Installation

1. Contractor shall excavate hole a minimum of 12 inches wider than outside of structure.
2. Structures shall be set to within +/- **0.03** foot of design grade.
3. For structures with precast bottoms, Contractor shall level bottom of excavation. Sand or aggregate base may be used. If greater than 1-1/2 inches thick, shall be moisture conditioned and compacted with vibraplate.
4. Grout structure to cast-in-place base. Structures set on wet concrete do not need to be grouted.
5. Contractor shall provide sediment basin of 1 to 2 inches depth in bottom of structure below invert of outfall pipe. Contractor shall fill with concrete and finish smooth if necessary.
6. Creating holes in existing structures shall be performed by coring where possible. If coring is not possible, the hole shall be created by using a rotohammer to make 1/2 inch to 1 inch holes approximately 2 inches apart at the outer circumference of the hole. After the holes have been rotohammered completely through the existing structure, the inside of the hole may be chipped out. Contractor shall not use jackhammer to create hole without predrilling as specified above first. Hole shall be 1 to 3 inches larger than outside diameter of pipe. Damaged structures shall be repaired as directed by the Owner.
7. CLSM or Cement Slurry backfill material may be used to fill the annular space around the pipe to within 2 inches of the inside of the structure. The last 2 inches of annular space shall be filled with a commercial non-shrink grout and finished smooth with the interior of the structure.
8. Pipes shall be trimmed to be flush (+/- 2 inch) with the inside of the structure.
9. Contractor shall backfill structure with CLSM or Cement Slurry.

- a. In landscape areas, Contractor shall place backfill to within 12 inches of surface. Contractor shall backfill remaining trench with topsoil compacted to eighty-five percent (85%) relative compaction.
- b. Under concrete, Contractor shall extend backfill to top of native material.
- c. In existing pavement areas, Contractor shall extend backfill to top of aggregate base.
- d. In new pavement areas, Contractor shall extend backfill to top of native soils.

3.3 FIELD QUALITY CONTROL

- A. Failure to install joints properly shall be cause for rejection and replacement of piping system.
- B. Contractor shall notify Owner twenty-four (24) hours in advance of backfilling system for inspection.
- C. Contractor shall remove covers and grates for interim and final inspections.

3.4 CLEANING

- A. Contractor shall clean storm drain system immediately prior to acceptance of project.
- B. Contractor shall clean all structures, new and existing, and pipe from all debris and/or sediment.
- C. Contractor shall remove asphalt, concrete or any other foreign substances from frame and covers or grates.
- D. Contractor shall clean through curb drain pipes up to a distance of 30 feet from curb face.

PART 4 PAYMENT

- A. Payment for work associated with storm drain improvements will be made on a unit price basis for the various items as listed in the Bid Schedule, including but not limited to pipe installation, drainage structure installation, and trench shoring. Pipe and structure clearing will be included in the various items of work unless specified otherwise in the Bid Schedule.
- B. Cleaning through curb drain pipes in excess of 30 feet will be paid as extra work.
- C. Said payments will be considered full compensation for furnishing all labor, materials, tools, equipment and incidentals, and for all related efforts to complete the work in place.

END OF SECTION

SECTION 31 23 00

EXCAVATION, GRADING & BACKFILL

PART 1 GENERAL

1.1 SUMMARY

- A. Work Shall Include but Not be Limited to the Following:
 - 1. Contractor shall perform rough and finish grading work required to prepare site for construction as described in Contract Documents.
 - 2. Contractor shall perform trench excavation and backfill for site utilities.
 - 2. Contractor shall perform excavating and compacting included in Project not covered under other Sections.
- B. Related Sections
 - 1. Section 02 41 13 - Site Demolition
 - 2. Section 32 00 01 - General Exterior Site Construction Requirements

1.2 QUALITY ASSURANCE

- A. Investigation
 - 1. **Contractor shall schedule a preconstruction meeting with Owner's Representative to discuss designed grades specific to this phase of Project.**
 - 2. Contractor shall identify benchmark to be used in establishing grades and review Contract Document requirements for grades, fill materials, and topsoil.
 - 3. Contractor shall examine site to pre-plan procedures for making cuts, placing fills, and other necessary work.
- B. Proof Rolling
 - 1. Contractor shall proof roll keyways, fills, and subgrades when requested to do so by Owner's representative.
- C. Compaction Testing
 - 1. Contractor shall schedule compaction testing with Owner's Representative at least forty-eight (48) hours prior to required testing.
 - 2. Contractor shall provide construction equipment to prepare testing sites. Minimum equipment shall be a rubber-tired backhoe or equivalently weighted rubber-tired machine.
 - 3. Contractor shall recompact all test locations if necessary.

PART 2 PRODUCTS

2.1 MATERIALS

- A. Site Material - Existing excavated material on site that has been identified as not being unsuitable as defined by Section 32 00 01 shall be suitable for use as fill material or backfill where allowed.
- B. Imported Fill/Backfill
 - 1. Quality shall be equal to or greater than quality of onsite material in terms of "R"

- Value, but not less than R=25.
- 2. Plasticity Index shall be less than 15 or no expansion pressure per CTM 301.

C. Imported Topsoil

- 1. Soil shall be fertile, loose, friable soil meeting the following criteria:
 - a. pH between 5.5 and 7.7
 - b. Soluble Salts - less than 2.0 mmhos/cm
 - c. Sodium Absorption Ration (SAR) - less than 3.0
 - d. Organic Matter - greater than one percent (1%)
- 2. Physical Characteristics:
 - a. Gradation shall be as defined by USDA triangle of physical characteristics as measured by hydrometer.
 - Sand - fifteen to sixty percent (15-60%)
 - Silt - ten to sixty percent (10-60%)
 - Clay - five to thirty percent (5-30%)
 - b. Soil shall be clean and free from toxic minerals and chemicals, noxious weeds, rocks larger than 1-1/2 inches in any dimensions, and other objectionable materials.
 - c. Soil shall not contain more than two percent (2%) of particles measuring over 2.0 mm in largest size.

D. Trench Backfill – CLSM per Section 32 00 01

E. Drain Rock

- 1. Drain rock material shall meet the following gradation requirements:

<u>Screen Size</u>	<u>Percentage passing</u>
1-1/2 inches	100
3/4 inch	5 (max.)
No. 200	2 (max.)

PART 3 EXECUTION

3.1 PREPARATION

- A. Before making cuts, Contractor shall remove topsoil over areas to be cut and filled that were not previously removed by stripping. Contractor shall stockpile this additional topsoil with previously stripped topsoil.
- B. Keyways for Fills
 - 1. Contractor shall prepare keyway at toe of fills.
 - 2. Keyways shall extend a minimum of 1.5 feet below adjacent undisturbed ground.
 - 3. Keyways shall be a minimum of 6 feet in width.
 - 4. Keyways shall slope between zero to four percent (0-4%) toward the fill.
 - 5. The bottom of the keyway shall be scarified, moisture conditioned, and compacted to ninety percent (90%) relative compaction at a minimum depth of 6 inches.
 - 6. Contractor shall proof roll for unstable or unsuitable soils.

3.2 PROTECTION

- A. General: Open excavations, trenches, and the like shall be protected with fences, covers, or railings as required to maintain safe pedestrian and vehicular traffic passage.

- B. Erosion of newly backfilled areas shall be prevented during construction. Settlement or washing that occurs in backfilled areas shall be repaired and grades reestablished to the required elevations.
- C. Contractor shall comply with all local, state, and federal stormwater protection regulations.

3.3 PERFORMANCE

- A. Tolerances
 - 1. Maximum variation from indicated grades for rough grading shall be **+/- 0.05 foot**.
 - 2. Grading shall not vary from the negative to positive tolerances within 50 feet.
 - 3. Contractor shall make proper allowances for final finish grades of pavement, top soil, planting areas, or other structures.
- B. When existing grade around existing plants to remain is higher than new finish grade, Contractor shall perform regrading by hand. Contractor shall not expose or damage existing shrubs or tree roots.
- C. Excavation
 - 1. Maximum cut slopes shall be 2H:1V or as shown on plans.
 - 2. Contractor shall round off top 3 feet of cut slopes
 - 3. Contractor shall not overcut slopes by more than 0.5 feet measured perpendicularly from the cut slope.
 - 4. Contractor shall protect existing trees and improvements from equipment damage.
 - 5. Finish slopes shall be graded smooth.
 - 6. Drainage: Contractor shall ensure proper drainage in and around excavation area. Contractor shall not allow water to accumulate in excavated areas. Water in excavation areas shall be removed by pumps or other means.
 - 7. Excavated material shall become property of the Contractor.
 - a. When fill is required elsewhere on site, Contractor shall use excavated material first prior to importing additional material unless excavated material is deemed unusable by the Owner's Representative.
 - b. If not called for reuse elsewhere on the site, excavated material shall be disposed of by the Contractor in a legal manner.
- D. Over-excavation
 - 1. Excavations below indicated depths will not be permitted, except to remove unsuitable material as identified in Section 32 00 01 of these Specifications.
 - 2. Satisfactory material removed below the depths indicated without specific direction from the Owner's Representative shall be replaced at no additional cost to the Owner to the indicated excavation grade. Replacement material shall be approved by Owner's Representative prior to performing the work.
- E. Trenching
 - 1. Contractor shall excavate to depth and alignment as shown on Plans.
 - 2. Bottom of trench shall be accurately graded to provide required slope and shall be stabilized if necessary, to provide a firm pipe bed.
 - a. Recesses shall be excavated to accommodate bells so that the pipe shall be uniformly supported for the entire length.
 - 3. Rock, where encountered, shall be excavated to a depth of 6 inches below the bottom of the pipe, and the void backfilled with clean fill sand.
 - 4. No joint trenching shall be allowed unless otherwise shown on Plans.
 - 5. Contractor shall provide shoring as required by Cal OSHA.
 - 6. Trench width shall equal pipe width plus 6 inches unless otherwise shown on Plans.

F. Subgrade Preparation

Site Tolerances

1. Maximum variation from indicated grades for rough grading shall be **+/- 0.05 foot**.
2. Grading shall not vary from the negative to positive tolerances within 50 feet.
3. Contractor shall make proper allowances for final finish grades of pavement, top soil, planting areas or other structures.
4. If soft spots, water, or other unusual and unforeseen conditions affecting grading requirements are encountered, Contractor shall stop work and notify Owner's Representative.

G. Fill Construction

1. Contractor shall uniformly moisture condition fill material to between optimum plus three percent (3%) optimum moisture prior to placing in fill.
2. Contractor shall place fills in maximum loose lifts of 8 inches.
3. Contractor shall compact fills to ninety percent (90%) relative compaction under concrete flat work areas; compact to ninety-five percent (95%) relative compaction under asphalt concrete paving. In landscape areas, Contractor shall compact to eighty-five percent (85%) relative compaction, and shall not over-compact.
4. Contractor shall correct any unstable areas.
5. Contractor shall compact fill slopes after trimming with three (3) passes of a sheepsfoot roller or track roll.
6. No fill or backfill material shall be placed during adverse weather conditions that will alter the moisture content to above optimum level.
 - a. Approved compacted subgrades that are disturbed by adverse weather or by the Contractor's actions shall be scarified and re-compacted to the required density prior to further construction thereon.

H. Trench backfill

1. CLSM or Cement Slurry per Section 32 00 01 of these Specifications, and as shown on Plans.
2. Contractor shall not perform any trench backfill until lines have been inspected and/or tested by Owner's Representative and authorization has been given to proceed by said Representative.

I. Finish Grading

1. Contractor shall not start finish grading until rough grading tolerances are met.
2. Prior to finish grading or adding topsoil to planters, Contractor shall dig out weeds by roots and remove rocks, concrete, asphalt, wood, forming material, wire, rubble, sticks, etc.
3. Prior to placing topsoil, Contractor shall remove aggregate base down to native soil in planting areas.
4. Contractor shall excavate planting areas to provide the following minimum topsoil depths below adjacent concrete or finish surfaces:
 - a. Lawn and Groundcover Planting Areas - 7 inches minimum
 - b. Shrub Planting Areas - 14 inches minimum.
5. Contractor shall redistribute approved existing topsoil stored on-site from stripping per Section 02 41 13.
6. Contractor shall add imported topsoil as necessary to provide required topsoil depth.
7. Contractor shall fine grade topsoil 1 inch minimum to 2 inches maximum below top of concrete or finish surfaces, unless shown otherwise on Plans. Contractor shall rake smooth and remove all lumps, rocks, etc.
8. Contractor shall provide a minimum of 8 inches clearance from finish floor at buildings or wood structures.
9. Contractor shall slope away from buildings at 1/2 inch per foot for a minimum of 5 feet.

10. Contractor shall fill low spots and pockets with topsoil and grade to drain.

J. Clean up

1. Upon completion of the work under this section, Contractor shall remove from the premises all surplus materials, tools, equipment, trash, rubbish, left-over material, and debris resulting from the work at their own expense and leave the site in a clean and neat condition satisfactory to the Owner's Representative.

PART 4 PAYMENT

A. Unless specified otherwise in the Bid Schedule, excavation, off haul, grading, and backfill will be paid for as a part of the various items of work and no separate payment will be made.

END OF SECTION

SECTION 31 32 13.19
LIME SOIL STABILIZATION

PART 1 GENERAL

1.1 SUMMARY

- A. Work Shall Include but Not be Limited to the Following:
 - 1. **Contractor shall schedule a preconstruction meeting with Owner's Representative to discuss designed grades specific to this phase of Project.**
 - 2. Contractor shall prepare subgrade as described in Contract Documents.
 - 3. Contractor shall stabilize and compact 2 feet of soil under building and transition areas as described in Contract Documents.
 - 4. Contractor shall stabilize and compact 12-inch layer of subgrade under remainder of site as described in Contract Documents.

- B. Related Sections
 - 1. Section 32 00 01 – General Exterior Site Construction Requirements
 - 2. Section 31 23 00 – Excavation, Grading, and Backfill
 - 3. Section 32 12 16 – HMA Paving

1.2 REFERENCES

- A. California Department of Transportation, Standard Test Methods
 - 1. Cal Test 216 "Method of Test for Relative Compaction of Untreated and Treated Soils and Aggregates."

- B. California Department of Transportation, Standard Specifications
 - 1. Section 24, Lime Stabilization

1.3 SUBMITTALS

- A. Product Data: Hi Calcium Quicklime by Chemical Lime Company, 4303 South McKinley Ave., Stockton, CA 95206 (800) 284-6048.
 - 1. Quicklime - Submit Certificate of Compliance.

- B. Samples
 - 1. Quicklime – Contractor shall submit 10 lb. sample in sealed and labeled container.

1.4 SEQUENCING

- A. Rough Grading - Rough grading shall be performed to allow for placement of lime-stabilized soil as described in the following paragraphs.

- B. Pavement Areas
 - 1. After rough grading is completed, Contractor shall perform lime soil stabilization in the designated building area to the specified depth.
 - 2. Lime soil stabilization shall be performed after completing all site utility work, including storm drainage; water and fire lines; irrigation piping and wiring; site lighting conduit; communication wiring; electrical services and site branch services; and all other underground facilities shall be installed, tested, and backfilled.
 - 3. Lime soil stabilization shall be performed prior to the construction of the site work concrete where these facilities are constructed on the lime-stabilized subgrade.

PART 2 PRODUCTS

2.1 MATERIALS

- A. On-site materials shall be stabilized and Quicklime shall conform to Section 24-1.02 of the latest edition of Caltrans Standard Specifications.
- B. Lime Content: 4.0 ± 0.5 percent by dry weight.

PART 3 EXECUTION

3.1 PREPARATION

- A. Contractor shall perform site preparation and rough grading in accordance with Section 31 23 00 to grade lines shown on Plans.

3.2 CONSTRUCTION

- A. Site Verification of Conditions
 - 1. Contractor shall complete all site work utility construction including testing.
- B. General Application
 - 1. Application and construction shall conform to Sections 24-1.03 through 24-1.06 of the latest edition of Caltrans Standard Specifications, except as noted.
 - 2. Maximum treatment and lift thickness shall be 12 inches.
 - 3. Spread rate shall be confirmed on each lift for each row of lime application until uniformity is confirmed by the Soils Engineer, and thereafter periodically, as needed to confirm uniformity.
- C. Compaction
 - 1. Contractor shall compact in 12-inch maximum lifts to ninety-five percent (95%) relative compaction at or above optimum moisture as determined by Cal Test 216.
 - 2. The maximum compacted thickness of a single layer may be increased provided the Contractor can demonstrate to the Soils Engineer that the equipment and method of operation shall provide uniform distribution of the lime and the required compaction density throughout the layer.
- D. Tolerances
 - 1. At a minimum, the completed lime-treated section, after compaction and trimming, shall be equal to the design thickness. The maximum completed lime-treated section thickness shall not exceed the design thickness plus 1 inch.
 - 2. Thickness/Uniformity Verification - Immediately after trimming and compaction are completed, Contractor shall excavate test pits. At locations selected by Soils Engineer, Contractor shall excavate a test pit for each 3,000 square feet of treated area. Test pits shall be 1 foot. by 1 foot. minimum, through lime-treated section. Contractor shall backfill with lime-treated material and compact immediately after verification of thickness and uniformity by Owner.
- E. Curing
 - 1. If not covered by asphalt concrete or aggregate base within forty-eight (48) hours, the exposed lime stabilized soil subgrade shall be covered with the appropriate emulsion seal as described in the referenced Caltrans Standard Specification sections within twenty-four (24) hours of completing lime stabilization.

3.3 PROTECTION

- A. Contractor shall maintain subgrade in a smooth, compacted condition until placement of aggregate. Contractor shall repair any damage to the lime-stabilized subgrade by immediately replacing with similar lime-treated material within twenty-four (24) hours after damage.
- B. Only rubber-tired vehicles or paving equipment shall be permitted on surface after compaction.

END OF SECTION

SECTION 32 00 01
GENERAL EXTERIOR SITE CONSTRUCTION REQUIREMENTS
PRIOR TO, DURING AND POST CONSTRUCTION

PART 1 GENERAL

1.1 SUMMARY

- A. Work Shall Include but Not be Limited to the Following:
 - 1. General procedures and requirements for Site Work.
 - 2. Accessibility Requirements

1.2 REFERENCES

- A. American Society For Testing And Materials (most recent revisions)
 - 1. ASTM D 1557, 'Test Method for Laboratory Compaction Characteristics of Soil Using Modified Effort'
 - 2. ASTM D 2216, 'Standard Test Method for Laboratory Determination of Water (Moisture) Content of Soil and Rock'
 - 3. ASTM D 2487, 'Standard Classification of Soils for Engineering Purposes (Unified Soil Classification System)'⁴
 - 4. ASTM D 6938, 'Standard Test Methods for In-Place Density and Water Content of Soil and Soil-Aggregate by Nuclear Methods (Shallow Depth)'
 - 5. ASTM D 2950, 'Standard Test Method for Density of Bituminous Concrete in Place by Nuclear Methods'
- B. Caltrans Test Methods (most recent revisions)
 - 1. CTM 216, 'Method of Test for Relative Compaction of Untreated and Treated Soils and Aggregates.'
 - 2. CTM 301, 'Method of Test for Determination of the Resistance "R" Value of Treated and Untreated Bases, Subbases and Basement Soils by the Stabilometer'
 - 3. CTM 304, 'Method of Preparation of Bituminous Mixtures for Testing'
 - 4. CTM 308, 'Methods of Test for Bulk Specific Gravity and Weight per Cubic Foot of Bituminous Mixtures'

1.3 DEFINITIONS

- A. Standard Specifications - Caltrans Standard Specifications **directly associated to the work.**
- B. Relative Compaction
 - 1. Ratio of field dry density as determined by ASTM D 2922 and ASTM D 3017 or 2216, and laboratory maximum dry density as determined by ASTM D 1557 or CTM 216F.
 - 2. Ratio of maximum field density as determined by ASTM D 2922 and the laboratory maximum density as determined by CTM 216G.
- C. Differing Subsurface or Physical Conditions
 - 1. Any subsurface or physical condition at or contiguous to the site that is uncovered or revealed either:
 - a. Is of such a nature as to establish that any "technical data" on which Contractor is entitled to rely as provided herein is materially inaccurate, or
 - b. Is of such a nature as to require a change in the Contract Documents, or
 - c. Differs materially from that shown or indicated in the Contract Documents, or

- d. Is of an unusual nature and differs materially from conditions ordinarily encountered and generally recognized as inherent in work of the character provided for in the Contract Documents.
 - 2. If Contractor believes that a differing subsurface or physical condition exists, Contractor shall promptly, after becoming aware thereof and before disturbing conditions affected thereby or performing any Work in connection therewith (except in an emergency), notify Owner's Representative in writing about such conditions. Contractor shall not further disturb such conditions or perform any Work in connection therewith until receipt of written order to do so.
- D. Unsuitable Material
 - 1. Soil or aggregate of such unstable nature as to be incapable of being compacted to specified density using ordinary methods at optimum moisture content; or
 - 2. Too wet to be properly compacted and circumstances not resulting from the Contractor's action or inaction prevent suitable in-place drying prior to incorporation into the work; or
 - 3. Otherwise unsuitable for the planned use.
- E. Unstable - visible deflection or movement either horizontally or vertically under loading of construction equipment or while being proof rolled.
- F. Proof Rolling - Using a loaded 10-wheel dump truck, water truck, or equivalent to load soil by driving slowly over areas designated by the Owner's Representative to check for unstable areas.

1.4 QUALITY ASSURANCE

- A. Owner will pay for all testing required by the project specifications.
- B. Contractor shall pay for cost of all non-complying testing.

PART 2 PRODUCTS

- A. Controlled Low Strength Material (CLSM)
 - 1. Contains maximum of 94 lbs of cement per cubic yard.
 - 2. Compressive strength between 75 and 150 psi at twenty-eight (28) days.
 - 3. Fly ash is permitted.
 - 4. Air entrainment additives for workability.
- B. Cement Slurry - Conforms to Section 19-3.062 of Caltrans Standard Specifications.

PART 3 EXECUTION

3.1 EXAMINATION

- A. Site Verification of Conditions
 - 1. Forty-eight (48) hours minimum prior to performing any work on site, Contractor shall contact Underground Service Alert (USA) to arrange for utility location services. If USA will not respond to the project site, the Contractor shall be required to provide a private locating service.
 - 2. Contractor shall perform minor, investigative excavations to verify location of various existing underground facilities at sufficient locations to ensure that no conflict with

the proposed work exists and sufficient clearance is available to avoid damage to existing facilities.

3. Contractor shall perform investigative excavating ten (10) days minimum in advance of performing any excavation or underground work.
4. Upon discovery of conflicts or problems with existing facilities, Contractor shall notify Owner's Representative by phone or email within twenty-four (24) hours. Contractor shall follow up by email notification with letter and diagrams indicating conflict or problem and sufficient measurements and details to evaluate problem.

3.2 PREPARATION

- A. Protection
 1. Spillage -
 - a. Contractor shall avoid spillage by covering and securing loads when hauling on or adjacent to public streets or highways.
 - b. Contractor shall remove spillage and sweep, wash, or otherwise clean project, streets, and highways.,
 2. Dust Control -
 - a. Contractor shall take precautions necessary to prevent dust nuisance, both on-site and adjacent to public and private properties.
 - b. Contractor shall correct or repair damage caused by dust.
 3. Existing Plants and Features - Contractor shall not damage tops, trunks, and roots of existing trees and shrubs on site that are intended to remain. Contractor shall not use heavy equipment within branch spread. Interfering branches may be removed only with permission of Owner's Representative. Contractor shall not damage other plants and features that are to remain.
- B. If Contractor does not make specified precautions or corrections and repairs promptly, Owner may take such steps as may be deemed necessary and deduct costs of such from monies due to Contractor. Such action or lack of action on Owner's part does not relieve Contractor from responsibility for proper protection of the Work.
- C. Contractor shall comply with all local, state, and federal stormwater protection regulations.

3.3 SURVEYING & LAYOUT

- A. Benchmark – Plans will provide either a permanent or temporary benchmark.
- B. Contractor shall provide all surveying and layout.
- C. Contractor shall provide two (2) personnel as requested by the Owner's Representative to perform quality assurance testing including stringlining of subgrades and verification of grades. Stringline and engineer's level (or laser level) shall be provided by the Contractor and shall be available at all times during site work.

3.4 REPAIR / RESTORATION

- A. Contractor shall adjust existing covers, boxes, and vaults to grade.
- B. Contractor shall replace broken or damaged covers, boxes, and vaults.
- C. Contractor shall independently confirm size, location, and number of covers, boxes, and vaults

- D. Contractor shall advise Owner's Representative of damage to underground site utilities. Contractor shall address utility repairs per Section 02 41 15 "Site Utility Repair".
- E. Site Cleaning Immediately Prior To Acceptance
 - 1. All surfaces shall be broom-clean and free from any accumulation of debris.
 - 2. Contractor shall clean tack coat on concrete surfaces. Tack coat within 1 inch of pavement on curbs or gutter shall not be required to be cleaned.
 - 3. Contractor shall remove all traffic control devices, excess materials, debris, and signage from site.
 - 4. Contractor shall remove all debris and sediment from the existing storm drain structures.
 - 5. Contractor shall clean existing through-curb drain pipes using ordinary methods such as a garden hose with extension pipes.
 - 6. Contractor shall bring clogged or damaged storm drain pipes or structures to the attention of Owner's Representative.
 - 7. Contractor shall replace any disturbed landscaping. Contractor shall backfill planters with clean topsoil and replace surface dressing or mulch in kind.
 - 8. Contractor shall remove all concrete debris and splatter.

3.5 ACCESSIBILITY REQUIREMENTS

- A. Work shall comply with the following code requirements:
 - 1. Title 24, CCR: California Building Code.
 - 2. Latest Edition of Uniform Building Code including California Amendments.
 - 3. Americans with Disabilities Act.
 - 4. Code requirements shall supersede plans or specifications.
- B. Coordination of Work
 - 1. Contractor shall coordinate work elements to provide code compliance.
- C. Accessible Travel Paths
 - 1. Include unloading zones, crosswalks, and sidewalks.
 - 2. Exclude ramps and landings.
 - 3. Maximum cross slope of two percent (2%).
 - 4. Maximum longitudinal slope of five percent (5%).
- D. Ramps and Landings
 - 1. Include all travel paths between 5 and 8.33 percent.
 - 2. Contractor shall provide handrails.
 - 3. Contractor shall provide wheel curbs or wheel rails.
 - 4. Contractor shall provide landings at beginning, end, and every 30 inches of vertical rise. Landings shall be a minimum of 72 inches long, the width shall match the travel path, and the maximum cross slope shall be two percent (2%).
- E. Curb Ramps
 - 1. Longitudinal slopes shall be between 6.7 and 8.33 percent.
 - 2. Cross slopes shall be less than two percent (2%).
 - 3. Concrete score marks shall be per code.
 - 4. Contractor shall provide positive drainage.
 - 5. Detectable Warnings shall be per ADA and codes.
- F. Door Landings
 - 1. Contractor shall extend landing 42 inches beyond door swing, and 24 inches beyond latch side of door.
 - 2. Maximum slope in any direction shall be two percent (2%).
 - 3. Maximum drop at doorways shall be 1/4 inch from finish floor to landing.

- G. Accessible Parking Stalls and Unloading Zones
 - 1. Maximum slope in any direction shall be two percent (2%).
 - 2. Unloading Zone shall be minimum 5 feet in width, 8 feet for Van Accessible Stalls.
 - 3. 6 feet Parking Bumpers shall be used to protect signs and overhang into accessible sidewalk, as necessary to provide a 4-foot minimum sidewalk width.

- H. Signage
 - 1. Signage shall include required entrance signs and stall signage.
 - 2. Signage location preference shall be building first, landscape area second, and in pavement third.

3.6 FIELD QUALITY CONTROL

- A. If work has been interrupted by weather, scheduling, or other reasons, Contractor shall notify Owner's Representative twenty-four (24) hours minimum prior to intended resumption of work.

- B. Owner reserves the right to require additional testing to re-affirm suitability of completed work, including compacted soils or aggregate bases that have been exposed to adverse weather conditions.

PART 4 PAYMENT

- A. Payment for all work described in this section will be included in the various items of work, and no separate payment will be made.

END OF SECTION

SECTION 32 01 26.71

COLD PLANING

PART 1 GENERAL

1.1 SUMMARY

- A. Work Shall Include but Not be Limited to the Following:
 - 1. Contractor shall cold plane existing asphalt concrete for transitions and conforms.
 - 2. Contractor shall remove digouts and repair areas.
 - 3. Contractor shall reduce the thickness of existing asphalt concrete pavements.
 - 4. The pavement to be cold planed may contain pavement fabric.

- B. Related Sections
 - 1. Section 32 00 01 - General Exterior Site Construction Requirements
 - 2. Section 32 12 16 – HMA Paving
 - 3. Section 32 12 16.05 - Hot-Mix Asphalt Repair

1.2 PRICE AND PAYMENT PROCEDURES

- A. Unit Prices
 - 1. The contract unit prices indicated in the Bid Schedule will apply to this work.

- B. Measurement and Payment
 - 1. Contractor shall provide documentation of lineal or area measurements.
 - 2. Contractor shall provide recycling certificate for grindings prior to payment if requested by Owner.

1.3 ADMINISTRATIVE REQUIREMENTS

- A. Coordination
 - 1. Contractor shall coordinate with affected utilities, transportation agencies, schools, waste disposal companies, and any other pavement users.
 - 2. Contractor shall coordinate with other contractors working on the site.

- B. Sequencing
 - 1. Contractor shall not commence cold planing until all stormwater protection BMPs are in place.

1.4 SUBMITTALS

- A. Contractor shall provide recycling facility information where grindings shall be disposed.

- B. If required, Contractor shall provide truck route for grinding disposal.

1.5 CLOSEOUT SUBMITTALS

- A. If requested by the Owner, proof of recycling with estimated quantity documentation shall be provided to the Owner prior to final payment.

1.6 QUALITY ASSURANCE

- A. Quality Assurance Inspection and/or Testing.

1. Owner may, at their option, have independent quality assurance inspection and testing.
 - a. Inspections may be made during or after the work.
 - b. QA Inspection and testing shall be for the sole purpose of providing the Owner a greater degree of assurance that the requirements of the contract have been met. QA inspection and testing shall not relieve the Contractor of any responsibility to comply with or perform in accordance with the Contract Documents.

1.7 PROJECT CONDITIONS

- A. Project Environmental Requirements
 1. Contractor shall not cold plane when precipitation is imminent.

PART 2 PRODUCTS - NOT USED

PART 3 EXECUTION

3.1 EXAMINATION

- A. Contractor shall visit the site to:
 1. Identify all utility surface features such as utility covers that are clearly visible to work crews.

3.2 PREPARATION

- A. Contractor shall layout transitions, conforms, and milling limits for Owner to review prior to proceeding with the work.
- B. Contractor shall lower utility facilities prior to reducing pavement thickness by cold milling.

3.3 EQUIPMENT

- A. Cold planer shall be equipped with automatic controls and sensing devices. Cold planers shall produce finished surface within 0.02 foot tolerance. The width of the cold planer shall match the smallest pavement removal area. Multiple cold planers may be used.
- B. Equipment shall be capable of cold planing concrete.
- C. Contractor shall maintain equipment by changing teeth as often as necessary to provide a smooth surface which meets the required tolerance.
- D. Cold planers shall be equipped with water spray devices to prevent the creation of dust.
- E. Cold planing equipment shall not be cleaned on site using water application unless specific measures for such cleaning have been addressed in the project SWPPP.
- F. Cold planer speeds shall adjust to provide longitudinal grind lines and avoid "V" shape grinding lines on the milled surface.

3.4 APPLICATION

- A. General
 1. All pavement grindings shall either be recycled or reused on-site if allowed by the

- specifications.
2. If the depth of pavement removal extends into native material, the removal shall be performed in two (2) steps to prevent contamination of the grindings with native material.
 3. Contractor shall prevent damage to gutter lips, curbs, or other facilities during cold planing. If necessary, Contractor shall use hand removal methods.
- B. Transitions
1. Contractor shall cold plane to width and depth as indicated on Plans and details.
 2. For full-depth transitions, cold planing may extend below existing asphalt pavement section into underlying base material to meet depth requirement.
- C. Pavement Repairs
1. Contractor shall remove pavement to the limits indicated on the Plans or as marked on the pavement by the Owner.
 2. If excess pavement is removed due to Contractor's equipment selection, excess area shall be replaced per specification without any additional expense to the Owner.
 3. The ends of the cold planed removal area need not be sawcut perpendicular to the pavement surface.
- D. Dust Control
1. Cold planers and sweepers shall maintain spray application to prevent dust at all times.
 2. Hand work areas shall use hand sprayers or other means to control dust.
 3. Dust control measures shall not create ponding of applied water on the pavement or runoff into the gutters or storm drain system.
- E. Finishing
1. Contractor shall remove remaining material between grinding edge and concrete surface edge (gutter, swale, sidewalk, etc.). Contractor shall remove high areas inaccessible to cold planer by jackhammer or other means.
 2. Contractor shall patch gouges or low areas by tack coating and filling with hot-mix asphalt. HMA shall be compacted using hand tamps or other means prior to the surface temperature of the patch falling below 250°F. Patching shall not be required if the area shall be covered by a leveling course of HMA.
 3. Contractor shall remove any asphalt or slurry seal material on adjacent gutters by scraping or other means approved by the Owner's representative.
- F. Temporary Transitions
1. Temporary transitions shall be placed prior to opening to traffic if the drop-off exceeds 0.10 feet.
 2. Temporary transitions shall be constructed of cold patch asphalt. The transitions shall be 2 feet minimum and have a slope of 20H:1V, whichever is greater.

3.5 TOLERANCES

- A. Contractor shall cold plane to limits and depths as follows:
- | | |
|--------------------------------------------|-------------------------|
| Vertical: | +/-0.02 feet |
| Horizontal: | +/- 0.5 feet |
| Adjacent Passes: | 0.02 maximum variance |
| Variance from Plane:
(Using Stringline) | 0.01' high to 0.05' low |
- B. Contractor shall correct any high areas by cold planing.

3.6 CLEANING

- A. Sweepers shall have dust suppression spray equipment working at all times.
- B. Contractor shall remove all grindings and debris immediately.
- C. Contractor shall clean pavement by power sweeping. Areas inaccessible to power brooms shall be cleaned using hand brooms or power blowers. If power blowers are used, Contractor shall prevent damage to vehicles, landscaping, and any other facilities. Contractor shall repair any damage to property owner's satisfaction.
- D. Contractor shall continue daily sweeping and cleaning until pavement is restored.
- E. Contractor shall clean drop inlet protections at the end of completion of cold planing. Contractor shall retain inlet protections in place until paving is completed.

END OF SECTION

SECTION 32 01 90.24

ROOT PRUNING

PART 1 GENERAL

1.1 SUMMARY

- A. Work Shall Include but Not be Limited to the Following:
 - 1. Contractor shall prune and remove existing roots as described in the Contract Documents and as specified on the Plans.
 - 2. Contractor shall remove roots under and adjacent to all damaged concrete to be removed and replaced.
 - 3. Contractor shall coordinate with Owner's designated Arborist if required by Contract Documents.

- B. Related Sections
 - 1. Section 32 00 01 - General Exterior Site Construction Requirements

1.2 SCHEDULING

- A. Contractor shall contact the Owner a minimum of forty-eight (48) hours in advance of backfilling operation to allow for Owner or representative to visually inspect root pruning and repair.

PART 2 PRODUCTS

PART 3 EXECUTION

- A. Preparation
 - 1. Contractor shall identify underground utilities by Underground Service Alert or locator service.
 - 2. Contractor shall pothole at potential conflicts to confirm depth to underlying utilities. Contractor shall notify Owner immediately of any conflicts.
 - 3. Contractor shall hand excavate trench at edge of removal area adjacent to tree.

- B. Pruning
 - 1. Contractor shall cut all roots within trench by hand (i.e. hand pruners or hand saw, axe, etc. **No Chain Saw shall be Allowed**)
 - a. Contractor shall trim and remove roots less than 2 inches in diameter encountered within limits of trench.
 - b. Contractor shall notify Owner of roots encountered in the trench measuring 2 inches or more in diameter. Contractor shall not remove unless directed to do so by Owner or Owner's Representative.
 - 2. In areas adjacent to existing trees, shrubs, or plant material to remain, Contractor shall perform excavation by hand to avoid damage to plant material.

- C. Root Removal
 - 1. Contractor shall not disturb roots between pruned end and tree.
 - 2. After pruning roots in trench, Contractor may remove remainder of cut roots outside the trench by any means.
 - 3. Backfill –
 - a. Topsoil as specified in Section 31 23 00.

PART 4 PAYMENT

- A. Root Pruning will be measured and paid for on a unit cost basis for "Root Pruning" as listed in the Bid Schedule and will be considered full compensation for all labor, equipment, and materials required to perform the work as described herein.

END OF SECTION

SECTION 32 11 23

AGGREGATE BASE

PART 1 GENERAL

1.1 SUMMARY

- A. Work Shall Include but Not be Limited to the Following:
 - 1. Contractor shall prepare pavement subgrade as described in Contract Documents to receive pavement base and paving.
 - 2. Contractor shall furnish and install pavement base in playground, driveway, and parking areas as described in Contract Documents.

- B. Related Sections
 - 1. Section 32 00 01 - General Exterior Site Construction Requirements
 - 2. Section 31 23 00 - Excavation, Grading & Backfill
 - 3. Section 32 01 26.72 - Cold Planing

1.2 REFERENCES

- A. Caltrans Standard Specifications, Section 26, 2010

1.3 SUBMITTALS

- A. Product Data - Manufacturer's published product data on soil sterilant.

- B. Quality Assurance / Control
 - 1. Contractor shall provide copies of test results from tests conducted to ensure compliance with Contract Document requirements.
 - 2. Contractor shall provide Certificate of Compliance for Aggregate Base

1.4 PROJECT CONDITIONS

- A. Project Environmental Requirements
 - 1. Contractor shall not perform work during following conditions:
 - a. Presence of free surface water or damp pavement.

PART 2 PRODUCTS

2.1 MATERIALS

- A. Aggregate Base
 - 1. New Aggregate Base shall be 19mm (3/4 inch) Class 2 aggregate base in conformance with Section 26 of the Caltrans Standard Specifications.
 - 2. Onsite Recycled Aggregate Base
 - a. By the Contract Documents or by approval from Owner's Representative, shall be pulverized existing asphalt concrete pavement mixed uniformly with existing aggregate base.

- b. Conform to following gradation

Sieve	Percent by Weight Passing Sieve
2-1/2 inch	100
1-1/2 inch	95 - 100
3/4 inch	60 - 100
No. 200	2 - 12
- c. Quality Requirements as established by testing
 - 1) R-value - 78 minimum

PART 3 EXECUTION

3.1 PREPARATION

- A. Contractor shall survey and stake paving surfaces to indicate grading required by Contract Documents.
- B. Sub-Grade
 - 1. Contractor shall finish grade surface area to grades required by Contract Documents.
 - 2. In pulverized areas where grading shall match existing, Contractor shall regrade onsite recycled base to match approximate grade of previous surface.
 - 3. Contractor shall compact as follows:
 - a. Under sitework concrete, concrete swales, concrete pads, or concrete pavement, Contractor shall compact to ninety percent (90%) relative compaction at optimum moisture +/- 2 percent.
 - b. Under HMA pavements, Contractor shall compact to ninety-five percent (95%) relative compaction at optimum moisture +/- 2 percent.
 - 4. Contractor shall proof roll completed subgrade prior to compaction testing and stringlining to verify subgrade stability. Contractor shall proof roll with full water truck or equivalent vehicle. Contractor shall repair unstable, soft, or yielding areas.

3.2 APPLICATION

- A. Site Tolerances
 - 1. Sub-Grade - 0.00 inches high. Contractor shall measure using stringline from curb to curb, gutter, flat drainage structure, or grade break.
 - 2. Base - The average base thickness shall be equal to or greater than the design thickness after compaction. The minimum base thickness shall be equal to the design thickness minus **0.03 ft.** The surface shall be graded to a finished tolerance of plus or minus 1/4 inch in 10 feet. Contractor shall measure using stringline from curb to curb, gutter, flat drainage structure, or grade break.
- B. Aggregate or Onsite Recycled Base
 - 1. Contractor shall grade to specified tolerances.
 - 2. Contractor shall compact as follows:
 - a. Under sitework concrete, concrete swales, concrete pads, or concrete pavement – Contractor shall compact to ninety percent (90%) relative compaction at optimum moisture +/- 2 percent.
 - b. Under HMA pavements, Contractor shall compact to ninety-five percent (95%) relative compaction at optimum moisture +/- 2 percent.
 - 3. Contractor shall remove and replace segregated areas.
 - 4. Contractor shall remove or repair improperly prepared areas as directed by Engineer.
- C. 1.. Overlay Transitions -

- a. Prepared per Section 32 01 26.72 "Cold Planing".
- b. Contractor shall place base course paving in full-depth transitions prior to overlay.

END OF SECTION

SECTION 32 12 16

HMA PAVING

PART 3 GENERAL

3.1 SUMMARY

- A. Work Shall Include but Not be Limited to the Following:
 - 1. Contractor shall Furnish and install Hot Mix Asphalt for areas as described in Contract Plans and Documents.

3.2 REFERENCES

- A. Caltrans Standard Specifications, Section 39, 2010 (Unrevised)

3.3 SUBMITTALS

- A. **HMA Submittals are due at preconstruction meeting**
- B. Product Data - Manufacturer's published product data on soil sterilant.
- C. Quality Assurance / Control
 - 1. Mix design of hot-mix asphalt mixture.
 - 2. Copies of test results from tests conducted to assure compliance with Contract Document requirements.
 - 3. Current verified **CEM 3513 including TSR value**

3.4 PROJECT CONDITIONS

- A. Project Environmental Requirements
 - 1. Contractor shall not perform work during following conditions:
 - a. Ambient, base, or pavement temperature below 50 degrees F.
 - b. Over-saturated base and sub-base materials.
 - 1) Base and sub-base to be wheel-rolled by loaded water truck to determine if any yielding occurs under the loading. If deflection is observed, Contractor shall not perform paving until grade is stable and unyielding.

PART 4 PRODUCTS

4.1 MATERIALS

- A. Pavement
 - 1. Asphalt Binder - PG 64-10
 - 2. Aggregates

- a. 3/4 inch Type A used for HMA base courses of 2-1/2 inches or thicker.
- b. 1/2 inch Type A used for base courses less than 2-1/2 inches, but greater than or equal to 1-3/4 inches and surface course in vehicle traffic areas.
- c. 3/8 inch Type A used for leveling courses and surface courses in playgrounds and other pedestrian areas.

B. Tack Coat

- 1. Tack coat shall be utilized and shall be emulsified asphalt Grade RS-1, RS-1h, SS-1, or SS-1h and shall conform to Section 94, 'Asphaltic Emulsions', of the Standard Specifications.

4.2 MIXES

A. Current verified and **PEI approved CEM 3513**

- 1. Mix voids targeted at 3.5%.
- 2. TSR to be minimum 70 in accordance with CTM 371.

PART 5 EXECUTION

5.1 PREPARATION

A. HMA Paving

- 1. **Contractor shall use self-propelled laydown machine for all surface courses. Laydown machine for finish course shall be equipped with automated depth and grade control.** Base courses for digouts or stabilization areas may be placed by other mechanical means that shall not destabilize subgrade.
- 2. Contractor shall heat joints if laid more than three (3) hours previously.
- 3. Compaction

a. Modify 39-2.03A Testing as follows:

“Quality Characteristic: Percent of maximum theoretical density (%) for HMA Type A to ninety-two percent (92%) to ninety-six percent (96%). Footnotes e & f shall be retained, and footnotes k through m shall be added to this requirement:

k. Contractor shall perform testing in accordance with CT 375 for acceptance, except CT 309 shall replace TMD testing.

l. Maximum lot size shall be 500 tons

1) Minimum 3 test sites per location, one (1) test for each 50 tons thereafter.

2) Each street segment or pavement area shall be an independent lot(s).

3) Compaction shall be the average compaction for the street or pavement area.

m. **Failing tests shall be verified by coring**, if requested by the Contractor. Contractor shall obtain cores at locations randomly determined by Engineer. Engineer will tests cores.

1) If requested by the Contractor and approved by the Engineer, non-nuclear gauges may be substituted for use in CT 375.

- b. If cores are passing, Owner pays cost of core sampling and core testing. If cores are failing, Contractor pays for testing and core sampling. If the core density

testing produces both passing and failing cores, the cost shall be prorated between the Owner and Contractor.

- c. The table for deductions indicated in the referenced Caltrans Section 39 shall apply to individual cores. The following table shall apply to deductions for average compaction of a lot:

Reduced Payment Factors for Percent of Maximum Theoretical Density			
HMA Type A Percent of Maximum Theoretical Density	Reduced Payment Factor	HMA Type A Percent of Maximum Theoretical Density	Reduced Payment Factor
92.0	0.0000	96.0	0.0000
91.9	0.0125	96.1	0.0125
91.8	0.0250	96.2	0.0250
91.7	0.0375	96.3	0.0375
91.6	0.0500	96.4	0.0500
91.5	0.0625	96.5	0.0625
91.4	0.0750	96.6	0.0750
91.3	0.0875	96.7	0.0875
91.2	0.1000	96.8	0.1000
91.1	0.1125	96.9	0.1125
91.0	0.1250	97.0	0.1250
90.9	0.1375	97.1	0.1375
90.8	0.1500	97.2	0.1500
90.7	0.1625	97.3	0.1625
90.6	0.1750	97.4	0.1750
90.5	0.1875	97.5	0.1875
90.4	0.2000	97.6	0.2000
90.3	0.2125	97.7	0.2125
90.2	0.2250	97.8	0.2250
90.1	0.2375	97.9	0.2375
90.0	0.2500	98.0	0.2500
< 90.0	Remove and Replace	> 98.0	Remove and Replace

- d. Field compaction testing shall be performed in accordance with CTM 375 with a minimum of five (5) tests per lot and one (1) test per 50 tons.
- e. Contractor shall roll with powered equipment capable of obtaining specified density and smoothness.
- f. **Contractor shall execute initial compaction rolling prior to mix cooling below 250 degrees.** Contractor shall complete finish rolling so visibility of joints is minimized as soon as possible after intermediate rolling and while asphalt paving is above 120 deg F surface temperature.
- g. **HMA that arrives at the job site at 260 degrees or below shall be rejected.**

4. Finish

- a. Surface shall be uniform with no 'birdbaths'. Contractor shall leave finished surfaces clean and smooth. Variations from specified grades shall not exceed 1/2 inch. When tested with 10-foot straight edge, surface of complete work shall not contain irregularities in excess of 1/4 inch.
- b. Completed surface shall match the texture of the machine-laid mat. Areas worked by raking shall have coarse aggregate removed rather than pushed back onto the mat. Any areas of coarse or segregated surface shall be remedied immediately and prior to finish rolling. **Failure to comply with this provision shall cause all paving to stop until mat surface corrections are performed.**

5. Thickness Tolerances

- a. Total HMA thickness less than or equal to 4 inches.
 - 1) **Minimum thickness shall be equal to or greater than design thickness**
- b. Total HMA thickness greater than 4 inches.
 - 1) **Minimum thickness shall be equal to or greater than design thickness**

PART 6 PAYMENT

Payment for HMA paving will be included in the various items of work in the Bid Schedule, including but not limited to digouts, overlays, pavement removal, and replacement, base course paving in full-depth transitions, and other items of work, and no separate payment will be made, therefor.

END OF SECTION

SECTION 32 12 16.05

HMA PAVEMENT REPAIR

PART 1 GENERAL

1.1 SUMMARY

- A. Work Shall Include but Not be Limited to the Following:
 - 1. Contractor shall remove and replace paving and/or base in specific areas as described in Contract Documents.
- B. Related Sections
 - 1. Section 32 00 01 - General Exterior Site Construction Requirements
 - 2. Section 32 01 26.72 - Cold Planing
 - 3. Section 32 12 16 - HMA Pavement

PART 2 PRODUCTS

2.1 MATERIALS

- A. Base - 3/4 inch Class 2 Base for below grade fill in accordance with Section 26 of the Caltrans Standard Specifications.
- B. **HMA 3/4 inch for Base course in dig outs, 1/2 inch for finish course in streets or parking areas, 3/8 inch finish course in Playground Areas** Type A per revised Section 39 of the Caltrans Standard Specifications.

PART 3 EXECUTION

3.1 PERFORMANCE

- A. Repair Of Deteriorated Pavement Areas
 - 1. Contractor shall cut edges of pavement in rectangular shape and for 1 foot minimum beyond damaged material. Contractor shall make vertical cuts using pavement saw or cold planer.
 - 2. Base - Contractor shall construct per Plans and Section 32 12 16.
 - 3. Contractor shall apply emulsion tack coat to vertical edges of existing asphalt and sitework concrete to be paved against.
 - 4. Paving -Lifts
 - i. Under overlays, Contractor shall place in single lift if less than 4 inch in depth.
 - ii. **If over 4 inches in depth, Contractor shall place in two (2) lifts. Minimum lift thickness including top lift shall be 1-3/4 inches in thickness.**
 - b. Longitudinal bituminous joints shall be vertical, and properly tack coated if not paved same day. Transverse joints shall always be tack coated if not paved same day. Contractor shall heat all cold joints on adjacent existing paving if previous mat was placed over three (3) hours prior to placement of current mat.

- c. Compaction -
 - i. Contractor shall compact per Section 32 12 16 HMA Paving.
 - ii. Contractor shall roll with powered equipment capable of obtaining specified density. Vibratory plate compactor may be used for areas too small for large power equipment.
- d. Surface shall be uniform with no 'birdbaths'. Contractor shall leave finished surfaces clean and smooth. Variations from adjacent surface shall not exceed 1/8 inch.

3.2 CLEANING

- A. Upon completion of repair operations, Contractor shall clean up and remove debris.

PART 4 PAYMENT

- A. HMA pavement repair will be measured and paid for on a square foot basis for "Digouts" and "Remove and Replace HMA" as listed in the Bid Schedule and will be considered full compensation for all labor, equipment, and materials required to perform the work as described herein.

END OF SECTION

SECTION 32 17 23

PAVEMENT MARKING

PART 1 GENERAL

1.1 SUMMARY

- A. Work Shall Include but Not be Limited to the Following:
 - 1. Contractor shall furnish material and apply pavement and curb markings as described in Contract Documents.
 - 2. Contractor shall remove existing pavement markings in sealcoat areas that will conflict with new striping layout.
- B. Related Sections
 - 1. Section 32 00 01 - General Exterior Site Construction Requirements

1.2 QUALITY ASSURANCE

- A. Regulatory Requirements - Contractor shall paint accessible parking spaces to conform to ADA Standards and local code requirements.
- B. **Contractor shall notify Owner's Representative forty-eight (48) hours in advance of paint application to allow for review of layout.**

1.3 SUBMITTALS

- A. Manufacturers Product Datasheet

1.4 PROJECT CONDITIONS

- A. Project Environmental Requirements
 - 1. Contractor shall apply pavement markings only on dry surfaces, during favorable weather, and when damage by rain, fog, or condensation is not anticipated.
 - 2. Latex Paint -
 - a. Atmospheric temperature above 50 degrees F.
 - b. When temperature is not anticipated to drop below 50 degrees F during drying period.
 - 3. Alkyd Paint -
 - a. Atmospheric temperature above 40 degrees F.
 - b. When temperature is not anticipated to drop below 40 degrees F during drying period.

PART 2 PRODUCTS

2.1 MATERIAL

- A. Paint
 - 1. Non-reflectorized.
 - 2. Types - Either Acrylic or Latex
 - 3. Colors -
 - a. Yellow - Parking stripes, crosswalk stripes, and safety markings.
 - b. Blue And White - Accessible Parking space markings.
 - c. Red - Fire lanes and no parking zones.
 - 4. Acceptable Products And Manufacturers -
 - a. 442XX Traffic Marking Paint by Devoe, Louisville, KY (800) 654-2616 Set-Fast Traffic Marking Paint by Sherwin-Williams, Cleveland, OH (800) 321-8194.
 - b. Equal as approved by Owner's Representative before installation.

PART 3 EXECUTION

3.1 PREPARATION

- A. Contractor shall not apply paint until hot-mix asphalt has cooled below 120 degrees F for at least one (1) hour.
- B. Surfaces shall be dry and free of grease and loose dirt particles. Contractor shall scrape and wire brush chipped or damaged paint on existing curbs. Contractor shall power wash curbs after paving but prior to painting with 3500 psi minimum pressure.
- C. Contractor shall perform layout with chalk or lumber crayon only. No blackout paint shall be allowed.

3.2 APPLICATION

- A. Site Tolerances
 - 1. General - Contractor shall make parking lot lines parallel, evenly spaced, and with sharply defined edges.
 - a. Line Widths - Parking Spaces 4 inch. Playground markings shall match existing layout and width prior to seal coat or Plan if on new pavement.
 - b. Plus or minus 1/4 inch variance on straight segments.
 - c. Plus or minus 1/2 inch variance on curved alignments.
- B. Contractor shall provide complete coverage in **one (1)** application at 75 sq ft per gallon, or **two (2)** coat application, each coat with maximum coverage of 150 sq ft per gal. Contractor shall not apply second coat within three (3) hours minimum or until first coat is thoroughly dried, whichever is longer.
- C. The underlying surface shall not be visible through newly applied paint.
- D. **Failure to produce satisfactory paint markings may require Contractor to provide a pavement coating to entire surface prior to the repainting of pavement markings.**
- E. Finished striping and marking shall not be applied until seven (7) days after final treatment has been completed and shall be applied within five (5) working days after the initial seven (7) days.

3.3 CLEANING

- A. Contractor shall remove drips, overspray, improper markings, and paint material tracked by traffic by sand blasting, wire brushing, or other method approved by Owner's Representative prior to acceptance.

PART 4 PAYMENT

- A. Parking lot striping will be paid for on a lump sum basis for "Pavement Markings" as listed in the Bid Schedule and will be considered full compensation for all labor, equipment, and materials required to perform the work as described herein.
- B. All work associated with cleaning and painting curbs, including placement of legends on curb faces, will be included in the lump sum price for "Pavement Markings" unless otherwise listed in the Bid Schedule.

END OF SECTION

SECTION 32 31 13

CHAIN LINK FENCING

PART 1 GENERAL

1.1 SUMMARY

- A. Work Shall Include but Not be Limited to the Following:
1. Contractor shall furnish and install complete fence as described in Contract Documents.

1.2 REFERENCES

- A. American Society For Testing And Materials
1. ASTM A 123-00, 'Standard Specification for Zinc (Hot-Dip Galvanized) Coatings on Iron and Steel Products'
 2. ASTM A 153-98, 'Standard Specification for Zinc Coating (Hot-Dip) on Iron and Steel Hardware'
 3. ASTM A 392-96, 'Standard Specification for Zinc-Coated Steel Chain-Link Fence Fabric'
 4. ASTM A 570-98, 'Standard Specification for Steel, Sheet and Strip, Carbon, Hot-Rolled, Structural Quality'
 5. ASTM A 1011-01, 'Standard Specification Steel, Sheet and Strip, Hot-Rolled, Carbon, Structural, High-Strength Low-Alloy and High-Strength Low-Alloy with Improved Formability'
 6. ASTM C 1107-99, 'Standard Specification for Packaged Dry, Hydraulic-Cement Grout (Nonshrink)'
 7. ASTM F 1043-00, 'Standard Specification for Strength and Protective Coatings on Metal Industrial Chain Link Fence Framework'
 8. ASTM F 1083-97, 'Standard Specification for Pipe, Steel, Hot-Dipped Zinc-Coated (Galvanized) Welded, for Fence Structures'

PART 2 PRODUCTS

2.1 MATERIALS

- A. Fabric
1. Chain link fabric of 9 gauge wire galvanized after weaving with 1.2-ounce zinc coating conforming to requirements of ASTM A 392, Class I, 2-inch mesh.
- B. Framework
1. Posts and rails shall be roll-formed, self-draining shapes meeting strength requirements of ASTM F 669, Table 3, and with 2-ounce zinc coating per sq ft of surface area conforming to ASTM A 123.

2. Line Posts - 2.375 inch outside diameter Schedule 40 tubular section weighing 3.65 lbs./lin-ft meeting requirements of ASTM F 1083.
3. Terminal And Gate Posts -3 inch outside diameter Schedule 40 pipe weighing 5.79 pounds per lineal foot meeting requirements of ASTM F 1083.
4. Top And Brace Rail - 1.660 inch outside diameter Schedule 40 pipe weighing 2.27 lbs./lin-ft meeting requirements of ASTM F 1083.
5. Fittings - Pressed steel or malleable iron, hot-dip galvanized conforming to ASTM A 153. Tie wires shall be 12 gauge minimum galvanized steel or 9 gauge minimum aluminum wire.
6. Tension Wire – 7-gauge minimum galvanized spring steel.

2.2 MIXES

- A. Post Foundation Concrete
 1. 1 cu ft cement, 2 cu ft sand, 4 cu ft gravel, and 5 gallons minimum to 6 gallons maximum water.
 2. Contractor shall mix thoroughly before placing.

PART 3 EXECUTION

3.1 INSTALLATION

- A. Fence shall be installed by mechanics skilled and experienced in erecting fences of this type and in accordance with Contract Documents.
 1. When general ground contour shall be followed, changes of grade shall be made in gradual, rolling manner.
 2. Evenly spaced posts in line of fence, shall be a maximum of 10 feet center to center.
- B. Post Foundations
 1. Except atop retaining walls, posts shall be set with concrete post foundations as specified below -
 - Line Posts -,Diameter 8 inches, Depth 36 inches
 - Gate, End, And Corner Posts - Diameter 12 inches, Depth 42 inches
 - a. At mow strips, top of post foundation shall be set below grade sufficiently to allow for placing of mow strip. Contractor shall measure post foundation depth from top of mow strip.
 - b. Where fences are incorporated into slabs, post foundation depth shall be measured from top of slab. Bottom of slab footing shall be extended sufficiently to allow specified amount of concrete around post. At existing slabs, Contractor shall install fence outside perimeter of slab.
 - c. For fences on retaining walls, 12 inch long sleeves shall be provided to be cast into retaining wall. Contractor shall set pipe in sleeve and grout space between sleeve and post full.

- C. Fence
 - 1. After posts have been permanently positioned and concrete cured for one (1) week minimum, Contractor shall install framework, braces, and top rail. Top rail shall be joined with 6-inch minimum couplings at not more than 21-foot centers.
 - 2. Fabric shall be stretched by attaching one end to terminal post and supplying sufficient tension to other end of stretch so slack is removed.
 - a. Fabric shall be fastened to line posts with tie wires. Contractor shall pass ties over one strand of fabric and hook under line post flange.
 - b. One tie shall be placed as close to bottom of fabric as possible with additional ties equally spaced between top and bottom band on approximately equal spacings not to exceed 14 inches on center.
 - c. Fabric shall be attached to roll-formed terminals by weaving fabric into integral lock loops formed in post. Contractor shall attach fabric to tubular terminals with tension bars and bands.
 - d. Fabric shall be held approximately 2 inches above finish grade line.
 - e. On top rail, tie wires shall be spaced at no more than 24 inches on center.
 - f. Fittings shall be secured, and nuts shall be firmly tightened.

3.2 CLEANING

- A. Contractor shall spread dirt from foundation excavations evenly around surrounding area unless otherwise directed. Contractor shall leave area free of excess dribbles of concrete, pieces of wire, and other scrap materials.

PART 4 PAYMENT

- A. Payment for chain-link fence installation will be paid for on a unit price basis as listed in the Bid Schedule. Said payment will be considered full compensation for furnishing all labor, materials, tools, equipment, and incidentals, and for doing all the work described herein.

END OF SECTION

SECTION 32 84 21

UTILITY SLEEVES

PART 1 GENERAL

1.1 SUMMARY

- A. Work Shall Include but Not be Limited to the Following:
 - 1. Contractor shall furnish and install utility sleeves as described in Contract Documents.
- B. Related Sections
 - 1. Section 32 00 01 - General Exterior Site Construction Requirements

PART 2 PRODUCTS

2.1 PIPE SLEEVES

- A. Size shall be as shown on Plans.
- B. Pipe shall be SDR 35 with elastomeric or welded couplings and caps.
- C. Marker Post shall be 4-inch x 4-inch x 3-inch pressure-treated post.

2.2 BACKFILL

- A. Under Pavement - CLSM or Sand Slurry per Section 02051.
- B. Landscape - Native soil.

PART 3 EXECUTION

3.1 INSTALLATION

- A. Depth
 - 1. Top of pipe shall be a minimum 21 inches below finished hot-mix asphalt pavement surface or 12 inches below base rock, whichever is greater.
 - 2. Top of pipe shall be a minimum 18 inches below sidewalks.
- B. Location
 - 1. Alignment shall be as shown on Plans.
 - 2. Sleeves shall extend a minimum of 6 inches into planter areas or under sidewalks.
- C. Construction
 - 1. Trench shall be a minimum of 6 inches wide.
 - 2. All debris shall be removed from trench.
 - 3. All couplings shall be welded, or elastomeric couplings shall be used. Caps shall be placed at each end of sleeve without welds.
 - 4. Marker post shall be placed abutting cap, plumb, and level at each end of pipe sleeve. Top of marker post shall be flush with adjacent sidewalk or ground surface and painted white.
 - 5. Pipe shall be secured to prevent floating while backfilling.

6. Contractor shall backfill to top of base rock, bottom of existing paving, or bottom of existing sidewalk.
7. CLSM or Sand Slurry shall not be allowed to flow into planter areas. Cut off form shall be used as necessary. Any backfill material protruding into landscape areas shall be removed before placing marker posts or backfilling with native.

PART 4 PAYMENT

- A. Utility Sleeves will be measured and paid for on a lineal foot basis for "PVC Pipe Sleeve" as listed in the Bid Schedule and will be considered full compensation for all labor, equipment, and materials required to perform the work as described herein.

END OF SECTION

SECTION 32 84 23

UNDERGROUND IRRIGATION SYSTEM

PART 1 GENERAL

1.1 SUMMARY

- A. Work Shall Include but Not be Limited to the Following:
 - 1. Contractor shall furnish and install underground sprinkler system as described in Contract Documents, complete with accessories necessary for proper function.
- B. Related Sections
 - 1. Section 32 00 01 - General Exterior Site Construction Requirements

1.2 SYSTEM DESCRIPTION

- A. Design Requirements
 - 1. Layout of Irrigation Heads and Dripline -
 - a. Location of heads and/or dripline shown on Plans are approximate. Actual placement may vary slightly as required to achieve full, even coverage without spraying onto buildings, sidewalks, fences, etc.
 - b. During layout, Contractor shall consult with Owner's Representative to verify proper placement and make recommendations where revisions are advisable.
 - c. Minor adjustments in system layout shall be permitted to avoid existing fixed obstructions.
 - 2. Valve stations shall be arranged to operate in an easy-to-view progressive sequence around site. Contractor shall record sequence on controller lid.
- B. Existing irrigation controller shall be replaced with a new controller with additional stations for adding new valves. New location, make, and model of new controller are shown on Plans.
- C. The improvements are designed to work by connecting to salvaged portions of the existing system. If existing system does not appear shall be in a condition that allows connection, Contractor shall notify Owner immediately.

1.3 SUBMITTALS

- A. Product Data
 - 1. Manufacturer's cut sheets for each element of system.
 - 2. Parts lists for operating elements of system.
 - 3. Manufacturer's printed literature on operation and maintenance of operating elements of system.
- B. Quality Assurance / Control - Contractor shall provide results of pressure test before beginning work on system.
- C. Closeout
 - 1. Record Drawings

- a. As installation occurs, Contractor shall prepare accurate record drawing shall be submitted before final inspection, including -
 - 1) Detail and dimension changes made during construction.
 - 2) Significant details and dimensions not shown in original Contract Documents.
 - 3) Field-dimensioned locations of valve boxes, quick-coupler valves, control wire runs not in mainline ditch, sleeve locations, and any other system facilities.
 - 4) Dimensions shall be taken from permanent constructed surfaces or edges located at or above finish grade.
 - 5) Dimensions shall be taken and recorded at time of installation.
 - b. Contractor shall provide two (2) copies of reduced record drawing to half-size, color key circuits, and laminated both sides with 5 mil thick or heavier plastic. Record drawing shall be delivered to Owner or Owner's Representative at completion of installation.
2. Instruction Manuals -
- a. Instruction manual that lists complete instructions for system operation and maintenance shall be delivered to maintenance personnel of the facility at completion of installation.

1.4 QUALITY ASSURANCE

- A. Regulatory Requirements - Work and materials shall be in accordance with latest rules and regulations, and other applicable state or local laws. Nothing in Contract Documents shall be construed to permit work not conforming to these codes.

1.5 DELIVERY, STORAGE, AND HANDLING

- A. During delivery, installation, and storage, materials shall be protected from damage and prolonged exposure to sunlight.

1.6 WARRANTY

- A. Standard one (1) year guarantee shall include -
 - 1. Filling and repairing depressions and replacing plantings due to settlement of irrigation trenches.
 - 2. Adjusting system to supply proper coverage of areas to receive water.

1.7 OWNER'S INSTRUCTIONS

- A. After system is installed and approved, maintenance personnel shall be instructed in complete operation and maintenance.

PART 2 PRODUCTS

2.1 MATERIALS

- A. Rock-Free Soil
 - 1. Soil shall be backfilled around PVC pipe.
 - 2. Soil shall have rocks no larger than 1/4 inch in any dimension.
- B. Pea Gravel
 - 1. Used around valves, quick couplers, and where shown on plans.
 - 2. 1/2 inch maximum round, water-worn, washed rock.

- C. Sand - Fine granular material naturally produced by rock disintegration and free from organic material, mica, loam, clay, and other deleterious substances.
- D. Native Material - Soil native shall project site free of wood and other deleterious materials and rocks over 1-1/2 inches.
- E. Topsoil - Existing in-place topsoil material or imported topsoil. Rocks, roots, sticks, clods, debris, and other foreign matter over 1-1/2 inches longest dimension encountered during trenching shall be removed.

2.2 COMPONENTS

- A. Pipe, Pipe Fittings, And Connections
 - 1. Pipe shall be continuously and permanently marked with Manufacturer's name, size, schedule, type, and working pressure.
 - 2. Pipe sizes shown on Plans are minimum. Larger sizes may be substituted without additional cost to Owner.
 - 3. Pipe -
 - a. Pressure Lines - Schedule 40 PVC.
 - b. Lateral Lines - Schedule 40 PVC.
 - c. Quick Coupler Piping - Galvanized steel
 - 4. Fittings - Same material as pipe.
- B. Sprinkler Heads
 - 1. Each type of head shall be product of single manufacturer.
 - 2. Contractor shall conform to requirements shown as to type, size, radius of throw, pressure, and discharge, and shall be equal as approved by Owner's Representative before bidding.
- C. Sprinkler Risers
 - 1. Pop-up sprinkler heads, shrub spray heads, bubbler heads, and stationary spray sprinkler heads shall have risers made up one of the following ways -
 - a. Three (3) schedule 40 street ells connected to lateral tee to form an adjustable riser or pop-up riser as detailed.
 - b. Risers for sprinkler heads 14 inches long minimum and 24 inches maximum.
 - 1) Acceptable Manufacturers -
 - a) Rainbird swing pipe with spiral barb fittings and street ell as detailed.
 - b) Funny Pipe by Toro
 - c) Equal as approved by Owner's Representative before installation.
- D. Automatic Sprinkler Control Wiring & Controller
 - 1. Control wire shall be UF-UL listed, color-coded copper conductor direct burial size 14. Green color-coded wire shall not be used.
 - 2. Waterproof Wire Connectors -
 - a. Acceptable Products and Manufacturers -
 - 1) DBY or DBR by 3M
 - 2) One Step' by King
 - 3) Equal as approved by Owner's Representative before installation.
 - 4) Controller as specified on Plans.
- E. Valves
 - 1. Electric Valves - Make and model shown on Plans.
 - 2. Quick Coupling Valve - Brass two-piece valve with locking top.
 - 3. Backflow Preventer - Make and model shown on Plans or as required by local code.
 - 4. Pressure Regulator - Make and model shown on Plans.

5. Pressure Reducer - Make and model shown on Plans.
- F. Valve Accessories
1. Valve Boxes -
 - a. Rectangular heavy-duty
 - b. Lock top or snap top lids.
 - c. Large enough for easy removal or maintenance of valves.
 - d. Use extensions as required.
 - e. Acceptable Manufacturers -
 - 1) Ametek
 - 2) Brooks
 - 3) Equal as approved by Owner's Representative before installation.
 2. Valve Box Support - Standard size fired clay paving bricks without holes.
- G. Dripline –
1. TLDL6-12 Techline by Netafim, with emitters at 12-inch spacing.
- H. Other Components
1. As recommended by Manufacturer and subject to Owner's Representative's review and acceptance before installation.
 2. Contractor shall provide components necessary to complete system and make operational.

PART 3 EXECUTION

3.1 EXAMINATION

- A. Site Verification Of Conditions - Pressure test shall be performed at stub-out where irrigation system is to connect on site. Owner's Representative shall be notified if pressures over 80 psi or under 40 psi are found to determine if some re-design of system shall be necessary before beginning work on system.
- B. Contractor shall coordinate with Owner's Representative for shutting off water prior to any connections to the existing water supply.

3.2 PREPARATION

- A. Protection
 1. Contractor shall repair or replace work of this Section damaged during course of the work at no additional cost to Owner. If damaged work is new, repair or replacement shall be performed by installer of original work.
 2. Existing tree roots measuring over 2 inches in diameter shall not be cut in order to install sprinkler lines.
- B. Plans show arrangement of piping. Should local conditions necessitate rearrangement, written approval of Owner's Representative shall be obtained before proceeding with work.

3.3 INSTALLATION

- A. Trenching And Backfilling
 1. Pulling of pipe shall not permitted.
 2. Trenches shall be over-excavated 2 inches and brought back to indicated depth by filling with rock-free soil or sand as specified under PRODUCTS. Rocks larger than 1-1/2 inches shall be separated out in any direction uncovered in trenching operation from excavated material and removed from areas receiving landscaping.

3. Pipe shall be covered, both top and sides, with 2 inches of rock-free soil as specified under PRODUCTS.
4. Pressure mains, sprinkler pipes, or fittings shall not be covered until Owner's Representative has inspected and approved system.

B. Installation of Pipe

1. Pipe shall be installed in a manner to provide for expansion and contraction as recommended by Manufacturer.
2. Unless otherwise indicated on Plans, main lines shall be installed with minimum cover of 18 inches based on finished grade. Remaining lateral lines shall be installed with minimum of 12 inches of cover based on finish grade.
3. Pipe and wires shall be installed under driveways or parking areas in specified sleeves 18 inches minimum below finish grade or as shown on Plans. All pipes under paved areas shall be sleeved as noted on the Plans.
4. Sprinkler heads immediately adjacent to mow strips, walks, or curbs shall be one inch below top of mow strip, walk, or curb and have one to 3 inches clearance between head and mow strip, walk, or curb.
5. Plastic pipe shall be cut square. Burrs at cut ends shall be removed before installation so unobstructed flow shall result.
6. Solvent weld joints shall be made as follows -
 - a. Solvent weld joints shall not be made if ambient temperature is below 40 deg F.
 - b. Clean mating pipe and fitting with clean, dry cloth and apply one coat of P-70 primer to each.
 - c. Uniform coat of 711 solvent shall be applied to outside of pipe.
 - d. Solvent shall be applied to fitting in a similar manner.
 - e. Light coat of solvent shall be applied to pipe and quickly inserted into fitting.
 - f. Pipe or fitting shall be given a quarter turn to ensure even distribution of solvent and that pipe shall be inserted to full depth of fitting socket.
 - g. Position shall be held for 15 seconds minimum or long enough to secure joint.
 - h. Solvent appearing at outer shoulder of fitting shall be wiped off.
 - i. Excessive amount of solvent thereby causing obstruction to form on inside of pipe shall not be used.
 - j. Joints shall be allowed to set at least twenty-four (24) hours before applying pressure to PVC pipe.
7. Threaded connections shall be taped with Teflon tape.

C. Control Valves and Controller

1. Controller, control wires, and valves shall be installed in accordance with Manufacturer's recommendations and according to electrical code.
2. Valves shall be installed in plastic boxes with reinforced heavy-duty plastic covers. Valve box tops shall be located at finish grade. No more than two (2) valves shall be installed in single box.
3. 6 inches minimum of pea gravel shall be placed below bricks supporting valve boxes to drain box. Pea gravel shall be extended 3 inches minimum beyond limits of valve box and maintained 4 inches minimum between bottom of valve and top of pea gravel. Valve boxes shall be set over valve so all parts of valve shall be reached for service. Cover of valve box shall be set even with finish grade.
4. Wiring -
 - a. All new control wiring shall be installed in Schedule 40 PVC pipe.
 - b. Waterproof wire connectors shall be used at splices and all splices located within valve boxes.
 - c. White or gray color shall be used for common wire and other colors for all other wire. Each common wire shall serve only one (1) controller.
 - d. One (1) extra control wire shall be run from panel continuously from valve to valve throughout system, similar to common wire for use if a wire fails. Wire shall be different color than all other wires, except use of green wire shall not

- be acceptable. Extra control wire shall be marked in control box as an extra wire. Extra control wires shall be extended 24 inches and left coiled in each valve box.
- e. A minimum of one (1) extra control wire shall be provided per ever four (4) valves or fraction thereof.

D. Sprinkler Heads

1. Before installation of sprinkler heads, control valves shall be opened and full head of water used to flush out system.
2. Sprinkler heads and quick-coupling valves shall be set perpendicular to finish grade.
3. Sprinklers shall not be installed using side inlets. Base inlets shall be used for installation only, unless approved otherwise in writing by Owner's Representative.
4. Sprinkler heads shall be set at a consistent distance from existing walks, curbs, and other paved areas and to grade.

E. Sleeving

1. Sleeving shall be installed as shown on the Plans and as described herein.
2. One (1) water pipe maximum shall be used per sleeve. Control wiring shall be sleeved in separate sleeve.
3. Sleeves shall be positioned with respect to buildings and other obstructions so pipe shall easily be removed.

F. Dripline – Lines shall be installed per Plans.

3.4 FIELD QUALITY CONTROL

- A. Site Tests - Before backfilling system, pressure lines shall be tested at 100 psi minimum for six (6) hours minimum to ensure there are no leaks. Owner's Representative shall be notified two (2) working days minimum before conducting test.

3.5 ADJUSTING

- A. Heads shall be adjusted to proper grade to ensure no appreciable harm will be caused due to walking on them. Such lowering or raising of heads shall be part of original contract with no additional cost to Owner.
- B. Sprinkler heads shall be adjusted (and dripline) for proper distribution and trimmed to prevent extreme overspray on adjacent walks, pavement, building, etc.
- C. Watering time of valves shall be adjusted to provide proper amounts of water to all plants.

PART 4 PAYMENT

- A. Installation of new systems will be paid for on a lump sum basis for "Underground Irrigation System" as listed in the bid schedule and will be considered full compensation for all labor, equipment, and materials required to perform the work as described herein.
- B. Modification of existing systems will be paid for as part of the lump sum price for "Landscape Restoration" as listed in the Bid Schedule and no separate payment will be made, therefor.

END OF SECTION

SECTION 32 91 13

SOIL PREPARATION

PART 1 GENERAL

1.1 SUMMARY

- A. Work Shall Include but Not be Limited to the Following:
 - 1. Contractor shall furnish and apply soil additives as described in Contract Documents.
- B. Related Sections
 - 1. Section 32 00 01 - General Exterior Site Construction Requirements
 - 2. Section 32 93 00 - General Planting Requirements

1.2 SUBMITTALS

- A. Product Data - Product literature and chemical/nutrient analysis of soil amendments and fertilizers.
- B. Samples - Contractor shall submit sample of soil conditioner and soil amendment for approval before delivery to site, and shall include product analysis list.
- C. Quality Assurance / Control - Contractor shall submit delivery slips indicating amount of soil conditioner delivered to Project site.

PART 2 PRODUCTS

2.1 MATERIAL

- A. Organic Soil Amendments and Application Rates
 - 1. Organic soil amendment
 - a. 5 cy per 1,000 square feet of Nitrolized soil amendment, minimum one percent (1%) over new planter areas.
 - b. Equal as approved by Owner's representative before installation.
- B. Acceptable Organic Soil Conditioners and Application Rates
 - 1. Contractor shall provide one (1) of following at 5 cu yds per 1000 sq ft -
 - a. EPA Class 'A' co-compost or compost with SAR less than 3.0, EC less than 4.0, and CN ratio of 15 to 25:1 passing through 1/2-inch mesh screen as approved by Owner's Representative prior to installation.
- C. Acceptable Fertilizers and Application Rates
 - 1. 6-20-20 pelletized fertilizer at 25 pounds per 1,000 sq ft.

PART 3 EXECUTION

3.1 PREPARATION

- A. Surface Preparation
 - 1. Seven (7) days maximum prior to beginning seeding and planting -

- a. Contractor shall loosen area 4 inches deep, dampen thoroughly, and cultivate to properly break up clods and lumps.
- b. Contractor shall rake area to remove clods, rocks, weeds, roots, and debris.
- c. Contractor shall grade and shape landscape area to bring surface to true uniform planes free from irregularities and to provide drainage and proper slope to catch basins.

3.2 APPLICATION

- A. Site Tolerances
 1. Contractor shall finish grade of planting areas prior to planting. After addition of soil additives, finish grade shall be specified distances below top of adjacent pavement of any kind -
 - a. Sodded Areas - 2 inches below
 - b. Seeded Areas - One inch below
 - c. Shrub And Ground Cover Areas - 1 to 2 inches below
 2. Any spots that settle shall be filled, and finished surface shall be regraded to conform to depths listed above.
- B. Specified soil amendments shall be added at specified rates.
 1. Amendments shall be roto-tilled or otherwise mixed evenly into top 6 inches of topsoil.
 2. Contractor shall incorporate and leach chemical soil amendments that require leaching, such as gypsum, within such time limits that soil is sufficiently dry to allow proper application of fertilizer and soil conditioners.
- C. Fertilizers and soil conditioners shall be applied over planting areas. Soil conditioner shall be roto-tilled into top 6 inches of topsoil until homogeneous mixture results.

3.3 FIELD QUALITY CONTROL

- A. Inspections - **Owner's Representative shall be notified forty-eight (48) hours minimum prior to roto-tilling in any soil additives.**

PART 4 PAYMENT

- A. Soil Preparation will be paid for on a lump sum basis for "Soil Preparation" as listed in the Bid Schedule and will be considered full compensation for all labor, equipment, and materials required to perform the work as described herein.

END OF SECTION

SECTION 32 93 00

GENERAL PLANTING REQUIREMENTS

PART 1 GENERAL

1.1 SUMMARY

- A. Work Shall Include but Not be Limited to the Following:
 - 1. General procedures and requirements for landscaping work shall apply.
- B. Related Sections
 - 1. Section 32 00 01 - General Exterior Site Construction Requirements

PART 2 PRODUCTS - Not Used

PART 3 EXECUTION

3.1 PREPARATION

- A. Protection
 - 1. Contractor shall take care in performing landscaping work to avoid conditions that will create hazards. Signs or barriers shall be posted as required.
 - 2. Contractor shall provide adequate means for protection from damage through excessive erosion, flooding, heavy rains, etc. Contractor shall repair or replace damaged areas.
 - 3. Site shall be kept well drained and landscape excavations dry.
 - 4. **Storm drain inlets shall be protected using approved BMP products.**

3.2 FIELD QUALITY CONTROL

- A. Inspection - Owner's Representative will review landscaping installation approximately one (1) week prior to end of maintenance period. Contractor shall replace landscaping that is dead or appears dead as directed by Owner's Representative prior to end of maintenance period. ***Landscaping repairs that are not made before the end of maintenance period may be cause to extend the maintenance period at the discretion of the Owner's representative.***

3.3 ADJUSTING

- A. Contractor shall replace damaged plantings at no additional cost to Owner.

3.4 CLEANING

- A. Contractor shall immediately clean up any soil or debris spilled onto pavement and dispose of all deleterious materials.

3.5 PROTECTION

- A. Contractor shall protect planted areas against traffic or other use immediately after planting is completed by placing adequate warning signs and barricades.

- B. Contractor shall provide adequate protection of planted areas against trespassing, erosion, and damage of any kind. This protection shall be removed after planted areas have been accepted by Owner's Representative.

PART 4 PAYMENT

- A. New work described in "General Planting Requirements" will be paid for on a lump sum basis.

END OF SECTION

SECTION 32 93 15

LANDSCAPE RESTORATION

PART 1 GENERAL

1.1 SUMMARY

- A. Work Shall Include but Not be Limited to the Following:
 - 1. Contractor shall restore landscape features impacted by other items of work.
- B. Related Sections
 - 1. Section 32 93 00 - General Planting Requirements

PART 2 PRODUCTS

- A. Components for Irrigation System Restoration shall be per Section 32 84 23 "Underground Irrigation System"
- B. Plant Material Restoration shall be per Section 32 93 05 "Exterior Plants"
- C. Top Dressing Mulch & Pre-Emergent Herbicide shall be per Section 32 93 05 "Exterior Plants"

PART 3 EXECUTION

3.1 RESTORATION TO IRRIGATION SYSTEMS

- A. Restoration -
 - 1. Sprinkler heads, irrigation valves, quick coupler valves, and other features that interfere with items of new work shall be relocated.
 - 2. Irrigation lateral lines shall be cut and capped where landscape area is converted to hardscape (sidewalk or paving).
 - 3. Irrigation lateral lines and/or pressurized mainlines shall be rerouted when conflicting with items of new work.
- B. Contractor shall perform all irrigation restoration work in accordance with Section 32 84 23 "Underground Irrigation System".

3.2 RESTORATION OF LANDSCAPE PLANT MATERIAL

- A. Restoration -
 - 1. Plants shown for temporary relocation shall be replaced at the completion of all other major work items of Project.
 - 2. Plants that have been damaged that are specified to be protected or to remain shall be replaced at no cost to the Owner. Minimum size for plant material restoration shall be as follows:

- a. Trees (up to 10 feet existing height) - 15 gallon container
 - b. Trees (greater than 10 feet existing height) - 36 inch box
 - c. Shrubs - 5 gallon container
3. **In lawn areas adjacent to work, Contractor shall replace turf up to edges of landscape areas. Turf shall be rolled sod to match existing turf grass as closely as possible. Only if approved by Owner's Representative, Contractor shall repair lawn areas by seeding.**
- B. All planting installation shall be performed in accordance with Section 32 93 05 "Exterior Plants".

3.3 MISCELLANEOUS LANDSCAPE FEATURES

- A. In landscape areas behind new sidewalk, curb, headerboards, and other site facilities, Contractor shall replace soil behind work to within 1 to 2 inches from finish surface.
 - 1. Existing site soil shall be used for backfill first, then imported topsoil per Section 31 23 00 "Excavation, Grading & Backfill" to supplement.
- B. After finish grading in affected planter areas, pre-emergent herbicide shall be applied, and top-dressing mulch shall be placed over all bare soil.
 - 1. Installation shall be performed per Section 32 93 05 "Exterior Plants."
- C. Existing landscaping boulders, stepping stones, and decorative features shall be replaced as specified on Plans.

PART 4 PAYMENT

- A. All work related to landscape restoration will be paid on a lump sum basis as listed in the Bid Schedule and will be considered full compensation for all labor, equipment, and materials required to perform the work as described herein

END OF SECTION

SECTION 32 93 23

LAWN SODDING

PART 1 GENERAL

1.1 SUMMARY

- A. Work Shall Include but Not be Limited to the Following:
 - 1. Contractor shall furnish and install sodded lawn as described in Contract Documents.
- B. Related Sections
 - 1. Section 32 93 00 - General Planting Requirements

1.2 DELIVERY, STORAGE, AND HANDLING

- A. Contractor shall harvest, deliver, store, and handle sod in accordance with requirements of 'American Sod Producers Association (ASPA) Specifications for Turfgrass Sod Materials and Transplanting/Installing.'
- B. Contractor shall cut and lift sod by method acceptable to Architect. Contractor shall cut sod in pieces, approximately 3/4 to 1 inch thick. Sod shall be rolled or folded so it may be lifted and handled without breaking or tearing and without loss of soil.
- C. Deliveries shall be scheduled to coincide with topsoil operations and laying. Storage shall be kept at job site to minimum without causing delays.
 - 1. Sod shall be delivered, unloaded, and stored on pallets within twenty-four (24) hours of being lifted.
 - 2. Small, irregular, or broken pieces of sod shall not be delivered.
- D. During wet weather, sod shall be allowed to dry sufficiently to prevent tearing during lifting and handling. During dry weather, sod shall be protected from drying before installation. Contractor shall water as necessary to ensure vitality and to prevent excess loss of soil in handling. Sod that dries out before installation will be rejected.

1.3 SEQUENCING

- A. Work of this Section shall not commence until work of Sections 32 84 23 and 32 91 13 have been completed, and approved by Owner's Representative.

PART 2 PRODUCTS

2.1 MATERIALS

- A. Certified Sod
 - 1. Sod shall be superior grown from certified, high-quality, seed of known origin or from plantings of certified grass seedlings or stolons.

- a. Contractor shall ensure satisfactory genetic identity and purity.
 - b. Contractor shall ensure overall high quality and freedom from noxious weeds or an excessive amount of other crop and weedy plants at time of harvest.
2. Sod shall be composed of two (2) varieties minimum of Kentucky Bluegrass.

PART 3 EXECUTION

3.1 INSTALLATION

- A. Site Tolerances - Final grade of soil after sodding of lawn areas shall be 1 inch below top of adjacent pavement of any kind.
- B. Laying of Sod
 1. Sod shall be laid during growing season. Sodding during dry summer period, at freezing temperatures, or over frozen soil shall not be permitted.
 2. Sod shall be laid within thirty-six (36) hours of being lifted.
 3. Sod shall be laid in rows with joints staggered. Sections shall be butt closely without overlapping or leaving gaps between sections. Irregular or thin sections shall be cut out with a sharp knife.
 4. Sod shall be laid flush with adjoining existing sodded surfaces.
- C. After Sodding is Complete
 1. Horizontal surface areas shall be rolled in two (2) directions perpendicular to each other.
 2. Areas with depressions, lumps, or other irregularities shall be repaired and re-rolled. Heavy rolling to correct irregularities in grade shall not be permitted.
 3. Sodded areas shall be watered immediately after laying sod to obtain moisture penetration through sod into top 4 inches of topsoil.

3.2 FIELD QUALITY CONTROL

- A. Inspection
 1. Sodded areas will be accepted at final inspection if –
 - a. Sodded areas are properly established.
 - b. Sod is free of bare and dead spots and without weeds.
 - c. No surface soil is visible when grass has been cut to height of 2 inches.
 - d. Sodded areas have been mowed at least twice.
 2. Areas sodded after November 1st will be accepted the following Spring (May 1st) approximately one (1) month after start of growing season if specified conditions have been met.

END OF SECTION